

# LOGOSOL USER MANUAL

USER MANUAL IN ORIGINAL FORMAT.

ARTICLE NO: 0458-395-0802



## LOGOSOL PH360



Read through the user manual carefully and make sure you understand its contents before you use the planer/moulder.



This user manual contains important safety instructions



**WARNING!** Incorrect use can result in serious personal injury or even death to the operator or others.

## Thank you for choosing a Logosol machine!

Welcome! We are very pleased that you have demonstrated your confidence in us by purchasing this planer/moulder and we will do our utmost to meet your expectations.

Logosol has been manufacturing sawmills since 1988, and since then we have supplied machines to satisfied customers worldwide. We want to assist you in safely achieving the very best possible results from your planer/moulder. We therefore recommend that you take the time to read this user manual from cover to cover before you begin using the machine.

Remember that the planer/moulder itself is just part of the value of the product. Much of the value is also to be found in the expertise we pass on to you in the user manuals. It would be a pity if that were not utilized.

We hope you get a lot of satisfaction from the use of your planer/moulder.

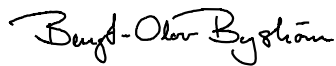

**Bengt-Olov Byström**

Founder and Chairman of the Board,  
Logosol AB



LOGOSOL is engaged in continuous development of its products.

We must therefore reserve the right to change the design and form of our products.

Text: Bo Mårtensson

Document: Logosol PH360 Manual

Image: Bo Mårtensson, Lars Wahlström

Last Revised: September 2014

Manual, product no. 0458-395-0802

© 2010 LOGOSOL, Härnösand Sweden

## Table of contents

Safety instructions	4
Tools required	6
Machine description	7
Preparations	7
Setup	8
Chip management	8
In and outfeed table	9
Starting the sawmill	9
Control panel	10
Bottom cutter	11
Top cutter	13
Molding knife in bottom and top cutter	15
Side cutters	16
Instruction variable	20
Maintenance	21
Setting the upper chassis' plan	22
Molding tips	22
Starter package PH360: molding knives & examples of combinations	23
Electrical schematic	26
Technical data	29
List of components	30
Overview	32
EC Declaration	43

## SAFETY INSTRUCTIONS

- Make sure that all warning and information stickers are in place, and that they are clean and legible. Any damaged stickers must be replaced immediately.
- Persons who do not have the necessary knowledge or experience of planers must not use this planer/moulder. This instructions do not constitute training in machine planing. Contact Logosol for information regarding training in machine planing.
- Ensure that non-authorized persons do not use this moulder.
- All protection must be assembled before the molder is used.
- Always use protective goggles and ear protection.
- Never use the molder if you are under the influence of strong medication, alcohol or any other strong drugs.
- Always check that knobs, screws, nuts, fences, sleeves, planing cutters, planing knives, etc. are properly tightened. Also check that the cutter can rotate freely and that there are no tools in or on the planer/moulder before it is started.
- Never use the planer/moulder in poor visual conditions such as bad lighting.
- Never place tools or hands into the in or outfeed areas when the planer/moulder is running.
- Never intervene in the planer/moulder before you have ensured that the power is switched off and the planer/moulder cannot be started accidentally.
- Small dimensions must be planed using fixtures, e.g. a piece of wood with a customized groove that extends along the full length of the table.
- Never stand along the the workpiece's extension line as kickback can occur, and bits of the workpiece can be thrown out of the planer/moulder. This applies to both the in and outfeed sides, although the risk is greater on the infeed side.

### KEY TO SYMBOLS



For your own safety, read the entire instruction manual carefully and do not start the planer/moulder before you have understood everything.



Use approved ear protection and protective goggles. Hearing can be damaged after only a short exposure



Sharp rotating tools. Be careful not to let your fingers get near the cutter.



This symbol means "WARNING!". Be extra vigilant when this symbol appears in the manual text.



This symbol is followed by a prompt. Be extra vigilant when this symbol appears in the manual text.

### PLANING/MOULDING

- Always measure the workpiece and set suitable thickness and width before planing.
- There is a high risk of accident if you feed in a workpiece that is not high enough for the feed rollers to get hold of the workpiece.

**GENERAL**

- Check the molder/planer as soon as you receive it. Report any transport damage to the transport company immediately.
- LIFT THE PLANER/MOULDER using a fork-lift or pallet jack.
- When replacing spare parts, use only original parts and note that anything electrical must be assembled by a qualified electrician.

**APPLICATIONS**

The planer/moulder can be used for planing/molding and planing wood, chipboard, board, etc.

Hard materials such as chipboard, teak, MDF, etc. require hard carbide tools, see the Logosol-Toolbox catalogue.

The planer/moulder is designed for indoor use, with temporary outdoor use.

**ENVIRONMENTAL REQUIREMENTS**

The temperature in the premises should be above freezing, unless special measures are taken.

Ventilation in the premises must be mechanical, and of a good standard.

The planer/moulder must be connected to a chip extractor, which is approved according to CE-standards, see page 10.

**SAFETY DISTANCE**



Other than the operator, no-one should be within 3 meters (10 foot) of the planer/moulder's sides or 8 meters (26 foot) from the in and outfeed sides during operation. Mark a limit that prevents anyone accidentally wandering into the risk area.

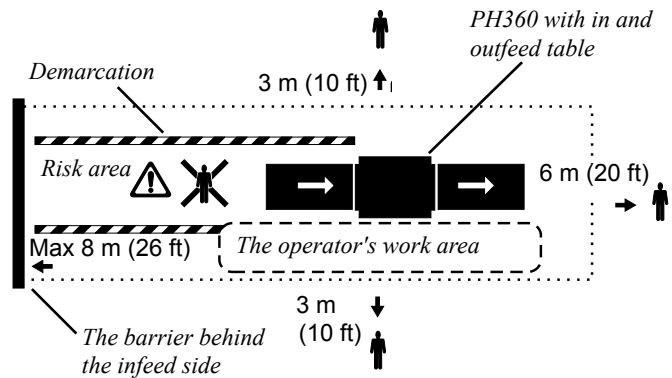

**TIPS:** An extended infeed table is practical to use, and prevents anyone coming into the risk area.

## TOOLS REQUIRED

### A LIST OF THE TOOLS REQUIRED TO BE ABLE TO WORK WITH THE PLANER/MOULDER:

Allen key 4 mm (supplied)  
 Allen key 5 mm  
 Allen key 6 mm  
 Open ended wrench 10 mm (supplied)  
 Wrench 10 mm  
 Ring wrench 13 mm  
 Open ended wrench 30 mm (supplied)  
 (for milling spindle)  
 Adjustable wrench 8" or 10"  
 (for milling spindle)  
 Sliding caliper  
 Measuring tape or ruler  
 Paraffin oil for the table  
 Whetstone

**Tips!** Make a tool board with the tools you need, and position it next to the planer/moulder so that you can see it easily. Look at the tool board before you start the planer/moulder to see if any tools are missing. They could have been left in the planer/moulder!

### THE FOLLOWING SPACER RINGERS ARE SUPPLIED:

3 x 40 mm height  
 2 x 20 mm height  
 2 x 10 mm height  
 1 x 5 mm height  
 2 x 2 mm height  
 1 x 1 mm height  
 1 x 0.5 mm height  
 1 x 0.3 mm height  
 1 x 0.2 mm height  
 1 x 0.1 mm height per cutter

These spacer rings allow you to set the required height.



## MACHINE DESCRIPTION

The PH360 is a planer/moulder that can work four sides of a workpiece in one action. The planer/moulder is contained in a stable and strong chassis. The planer/moulder table and slide for the moving cutter are made of planed cast iron.

The workpiece is fed, lying on the planer table, through the planer by four feed rollers as well as an outfeed roller. The rollers are driven by a chain transmission with separate motor. The workpiece is controlled laterally with adjustable fences and pressure rollers.

The work is done using a top cutter and a bottom cutter, that are hung at both ends, as well as two side cutters which are fixed to the planer table. All the cutters are driven by separate motors, via a belt transmission.

The cutters and feed rollers are covered by a foldable protective cover plate with window. The cover plate is supplied with a safety switch. Another safety switch sits behind the top edge of the cover plate on the infeed side. A 100 mm (4") hose is connected to the bottom and side cutters and a 125 mm (5") hose is connected to the top cutter with the option of an additional 100 mm (4") for connection to the chip extractor.

### TABLE SURFACE

The table is cast in the highest quality. The table surface is specially processed for the highest precision and the best anti-friction qualities. When the planer/moulder is new, it requires a driving-in period until the table gets a slightly shinier surface to optimize the anti-friction qualities. During this period, we recommend that you use a lubricant or wax on the table.

## PREPARATIONS

Certain parts are not assembled on delivery for transport and packaging reasons.

1. Assemble the control panel in place with the arm where the cabling goes, (232), (251).
2. Assemble all safety doors.
3. Assemble the infeed table (212). [Figure 1]
  - Screw down all adjustable screws (B) in the bottom.
  - Insert all screws (A) tighten by hand.
  - Insert the adjustment screws (C) and adjust the table so it is straight.
  - Adjust exactly: The highest position of the infeed table must be on the same level as the cast machine table. Check with a long, straight fence rail.
  - Adjust the height of the table so that it touches the cast iron table with the adjustment screws (B) and tighten the holding screws (A).
  - Check the table angle and table height and insert the table fixture's bottom lock screws (D) which are fastened using nuts on the inside of the chassis.
4. Assemble the outfeed table (253). [Figure 2]
5. Assemble the side fences [Figure 3]
6. Connect the planer/moulder to the chip extractor.
7. Before the planer/moulder is connected to the electrical circuit, check that all cutters can rotate freely, and that all parts are fixed.

Figure 1.

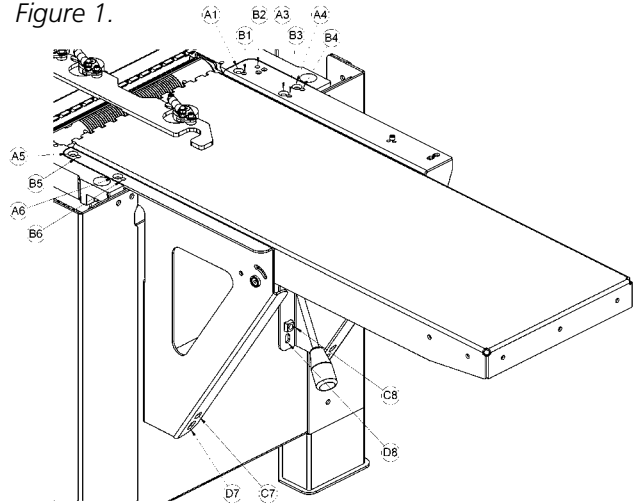

**Hole pattern key:**

- A: Holding screws for the infeed table.
- B: Holes for accessing the adjusting screws where the screw head lies under the table fixture.
- C: Threaded hole for adjustment screws for setting the table angle.
- D: Hole for lock screws.
- E: Fixing point for adjustable side fence. A double hole pattern means that the fence can be placed in an outer or inner position

Figure 3.

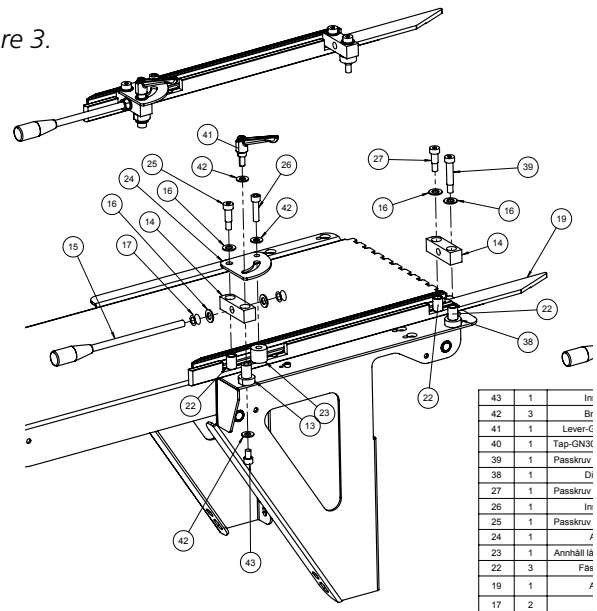
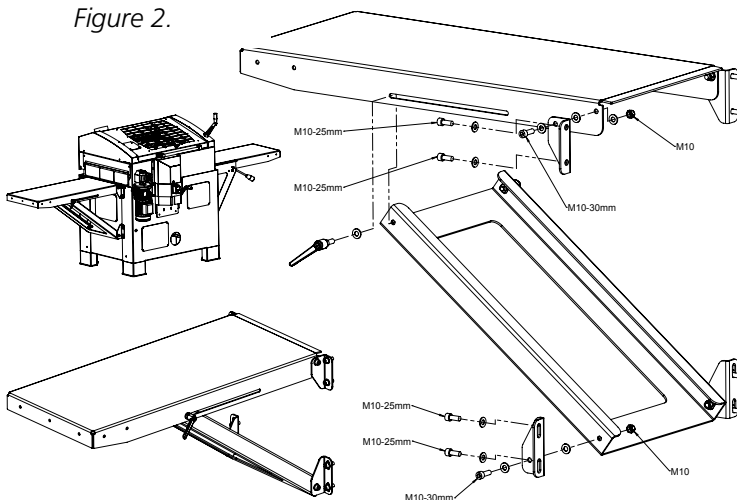

Figure 2.



## SETUP

Check your PH360 as soon as you receive it. Any transport damage must be reported to the transport company immediately.

Most of the planer/moulder is protected against rust, but it will require extra maintenance in the form of lubrication for all the parts not protected against rust. See the Maintenance section.

- Place the planer on a stable and flat base. Preferably screw the planer down using the holes in the base, if the castor set is not used.
- Ensure that there is enough space for the longest boards you want to plane at the in and outfeed sides, and that there is enough space for maintenance and timber stocks.
- Connect the chip hoses and fix using the hose clips on the planer and fan.

- Hang the planer's electrical cable on the ceiling or protect it in another way. Never step on the cable. The planer/moulder should be connected via an earth-fault protection switch.
- Ensure that lighting is good. There should also be good general lighting. Also set up a strong lamp directly over the planer. Ensure that there is no risk of glare.

### SPACE REQUIREMENTS

The planer/moulder needs a space of at least 2 m (6 1/2 ft) wide. The length required depends on the length of the workpieces you want to plane. The minimum length is 4 m (13 ft).

### ANCHORING

For the highest safety, the planer/moulder must be anchored to the floor using screws. Screw diameter 8-10 mm (3/10" - 4/10").

## CHIP MANAGEMENT

The PH360 must be connected to a chip fan with a capacity of at least 3,000 m<sup>3</sup>/h (10,000 cubic feet/hr) . Logosol has a range of pipes, sleeves and hoses. Ask our advice.

Remember that you need an air vent in your chip container (e.g. a fine net or filter if you carry out chip collection indoors). Poor suction is often due to poor airflow from the chip container. If you work in heated premises, remember that the fan will quickly cool the space if you do not lead the filtered air back into the building. Consideration must be taken for fire risk and dust emissions (discharge) in connection with chip collection.

 Fire risk and dust emission in connection with chip management.

 Contact the local authorities for advice in designing a chip collection system to conform with rules in your area.

 Position the chip fan so that you can easily reach the switch.

 Chips that are left in the planer/moulder must be vacuumed up after every work session.

### TECHNICAL REQUIREMENTS CHIP EXTRACTOR

- The chip extractor must be approved according to the CE-standard.
- The airflow "without external connection" must be approx. 4000-5000 m<sup>3</sup>/hour (13,000-16,500 cubic feet/hour).
- (The manufacturer's standard indication of airflow.)
- The sleeve diameters for the planer = 100 mm (4") x 4 and 125 mm (5") x 1.
- The pressure loss in the planer is 26 mm of water column at 25 m/s (1 inch of water column at 82 ft/s) .



## IN AND OUTFEED TABLE

Note that the outfeed table can easily be folded up so you can move around the planer.

The tables must mainly be completely in line with one another (when the cut in the bottom cutter is 0 mm (0") but in certain cases it can be an advantage for the ends of the feed table to lie slightly higher (1-5 mm) than the planer table to reduce in and

outfeed marks (snipe). This particularly applies when thin or soft workpieces are being processed. The outer edges must then always lie slightly higher than the planer table.

It is extremely important that the infeed table, planer table and outfeed table are correctly setup so that there are no cutter marks on the ends of the object.

## STARTING THE PLANER



Risk of serious damage.



Check that no tools have been left in the planer.



Check that all screws have been sufficiently tightened.



Check that the cutters can rotate freely before the safety doors are closed.



Do you remember the warning instructions on pages 4-5?

### Before starting:

- Ensure that all cutters can rotate freely.
- Ensure that the emergency stop (a11) is pulled out.
- Ensure that the top door is closed, and impacts the door switch (179).
- Check that no-one other than the operator is inside the safety distance.



Connect the planer electrically. Watch the rotational direction. If you are standing by the feeder gears, the rotational direction of the top cutter must be counter-clockwise.

## CONTROL PANEL

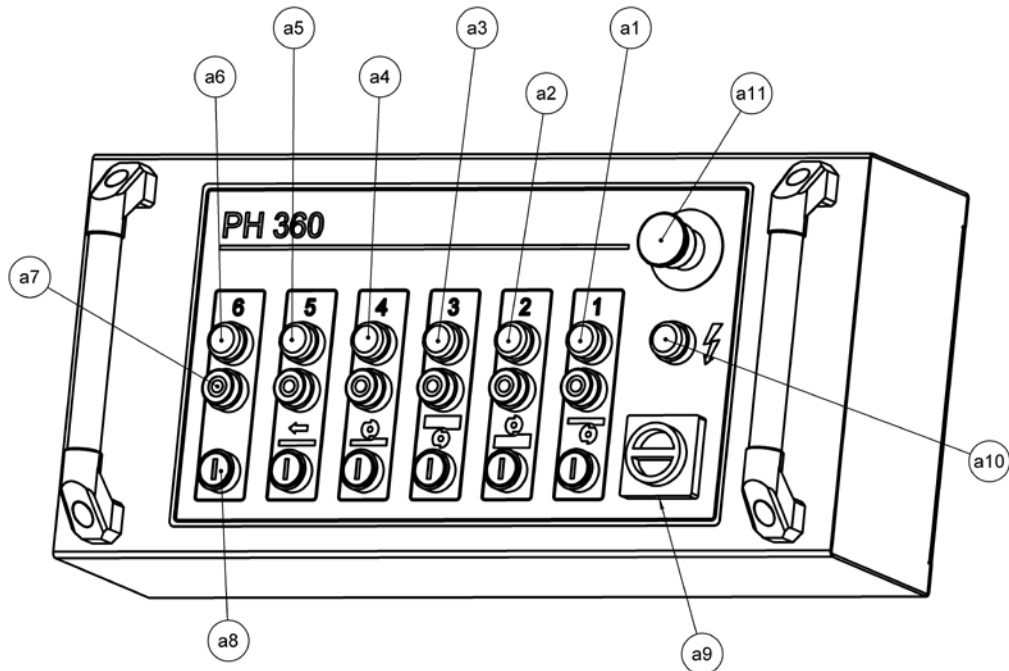

### CONTROL PANEL

The top red button (a11) is the emergency stop and switches off the power to all functions. When the emergency stop is used, it must be pulled out again in order for the planer/moulder to be re-started.

Under the emergency stop is a light (a10) which indicates that the power supply is connected. When replacing knives and during servicing, for example, the power switch (a9) must be in the off position. Check that the light (a10) is not lit.

The bottom black row of buttons (a8) start the planer's motors. The top red row of buttons (a7) stops the planer's motors (a7). Above each button there is a light (a6) which indicates that the relevant motor is running.

### The button's function is from the right:

1. Starting the planer cutter (lower horizontal cutter)
2. Starting the side cutter, right
3. Starting the side cutter, left
4. Starting the planer cutter (upper horizontal cutter)
5. Starting the feed
6. To control extra motors, or a fifth cutter

## BOTTOM CUTTER

**!** Before you open the safety doors on the planer, ensure that the power is switched off and that the cutters are not rotating. Use protective gloves, particularly when you need to loosen screws that are tightly fastened, or when you are tightening screws (see warning instructions). Beware of the planer knives. It is extremely easy to cut yourself on these, even with the slightest touch.

The bottom cutter is fixed to the planer table on the planer's infeed side. Two planer knives are mounted in two of the bottom cutter's tooling slots on delivery (planer knife 410 mm (16") HSS, item no. 7000-002-8410). Another two planer knives, or molding knives can be mounted in the two empty tooling slots.

### SETTING THE BOTTOM CUTTER'S CUT

The cut of the bottom cutter is set using a lever (211). Locking is done using a lever (224).

The normal cut on the bottom cutter is 2 mm (8/100").

### DISASSEMBLING THE PLANER KNIFE

The planing knife is disassembled by loosening the chip breaker's (A) lock screws (B) and then unscrewing the planing knife with adjuster screws (C).

### GRINDING THE PLANING KNIFE

Always grind the knives in pairs, so they are the same height, min. 15 mm (.600"), otherwise vibrations could occur in the cutter. The grinding angle must be 38 degrees. You can order a grinder from Logosol for sharpening molding and planing knives (Tormek Grinder, item no. 7010-000-1000, Jig for planing knives, item no. 7010-000-1005).

### ADJUSTING THE BOTTOM CUTTER'S PLANING KNIFE

The bottom cutter's planing knife must be set so that it is on the same level as and in line with the planer table.

- Loosen the chip breaker's lock screws (B) that are found in the groove between the chip breaker (A) and the cutter using a 10 mm (4/10") key (supplied). After this the knife can be raised or lowered using the two adjustable screws (4 mm socket head) (C) that are recessed by the cutter's keyway. Use a 4 mm socket head screw (supplied). The knife must stick out 1 mm (.040") from the cutter body to align with the molding knife from Logosol.
- Check the level of the knife by placing a bit of planed edging on the planer table behind the cutter. The cutter's knife should then touch the edging (see image below). Another method is to

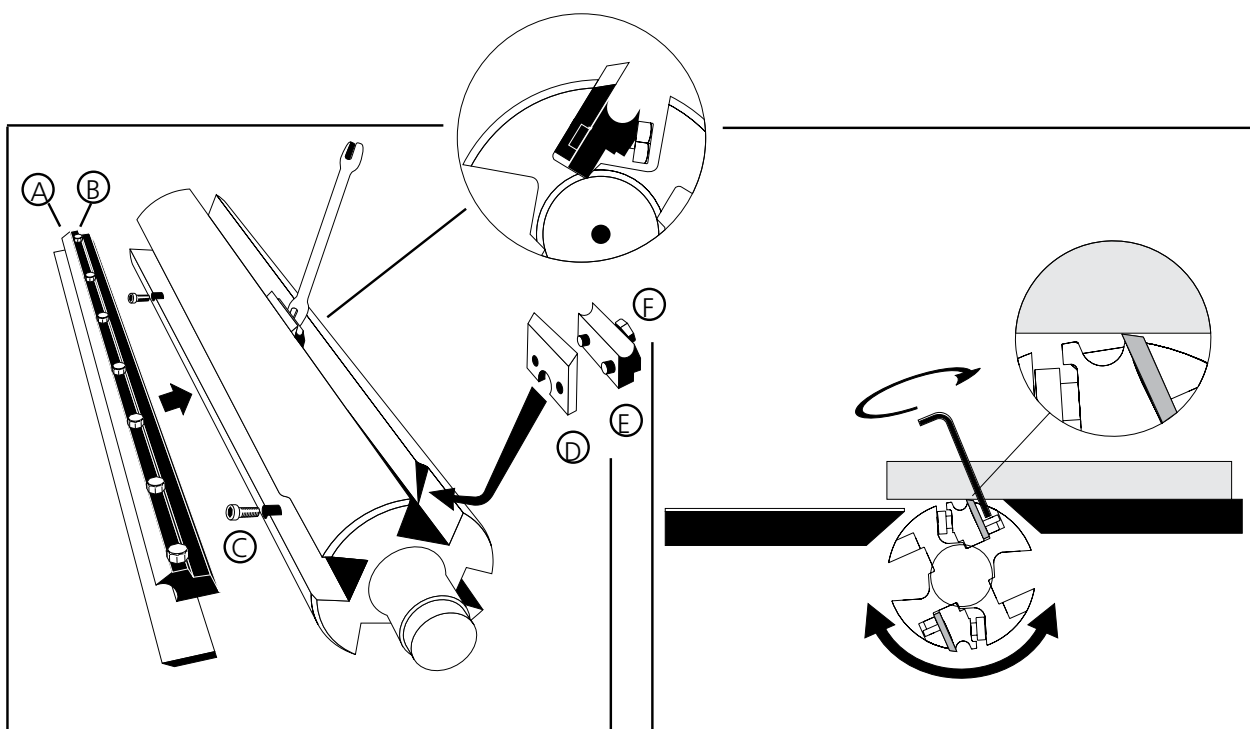

use a magnetic knife setter (magnetic adjuster, lower cutter, item no. 7500-001-0051): Loosen the chip breaker's lock screws and tighten the knife's adjustable screws several turns. Rotate the cutter so that the planing knife is in its uppermost position. Place the magnetic adjuster straight and in a V-shape on the planer table behind the cutter so that the knife edge is directly under the magnetic adjuster's magnets. Set up the adjustable screws until you feel that the knife is lifted by the magnet, so that it reaches the correct level. Tighten the lock screws and then carefully screw the adjustable screws so that they fix the knife in this position.

- Tighten the screws locking the knife in position counter-clockwise (i.e. out of the keyway). Start by tightening carefully. Move from the sides and in towards the middle, retightening them later.
- Carefully screw the adjustable screws in the bottom of the knife's recess. If you tighten these too hard, the knife will crack.

**After adjusting or replacing planing knives:**



Check that no tools have been left in the planer.



Check that all screws have been sufficiently tightened.



Check that the cutters can rotate freely before the safety doors are closed.



Do you remember the warning instructions on pages 4-5?

## TOP CUTTER

**!** Before you open the safety doors on the planer, ensure that the power is switched off and that the cutters are not rotating. Use protective gloves, particularly when you need to loosen screws that are tightly fastened, or when you are tightening screws (see safety instructions). Beware of the planer knives. It is extremely easy to cut yourself on these, even with the slightest touch.

### SETTING THE CUT OF THE TOP CUTTER

The planer thickness is set using the planing table crank (189). The set thickness can be read on the indicator (109) on the machine stand. The indicator can be calibrated. Plane some wood and adjust the top cutter until you get the correct height. Release the green cover (168). The ring above the indicator has a stop screw. Turn the ring so that it shows the planing height that has been planed.

The top cutter is fixed to the chassis and hung at both ends. Two planing knives are mounted in two of the bottom cutter's tooling slots on delivery (planer knife 510 mm (20") HSS, item no. 7000-002-8510). Another two planing knives, or molding knives can be mounted in the two empty tooling slots.

Always set the top cutter uppermost to reduce any slack in the threads. If the top cutter needs to be lowered, lower it half a rotation too low and then raise it into the correct position. Once you have the top cutter set at the correct height, you can lock it in position with the handle to the right of the feed motor assembly.

### DISASSEMBLING, ASSEMBLING AND GRINDING PLANING KNIVES

See above, under the Bottom cutter section. Exceptions: The minimum height of the planing knives are different. Make sure you're using the right Setting Block.

#### After adjusting or replacing planing knives:

- !** Check that no tools have been left in the planer.
- !** Check that all screws have been sufficiently tightened.
- !** Check that the cutters can rotate freely before the safety doors are closed.

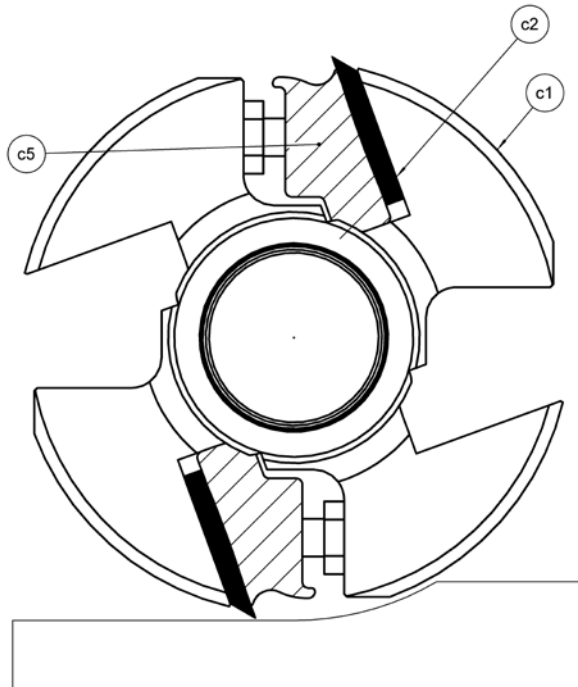

**!** Do you remember the warning instructions on pages 4-5?

### ADJUSTING PLANING KNIVES

Adjust the planing knives so that they are the same level and protrude 1 mm (.040"). This is done using an aluminum adjustment block (item no. 7500-000-1020), found in the component packaging on the planer table when the planer/moulder is delivered.

Loosen the chip breaker's lock screws slightly, and place the adjustment block over the knife. Adjust the knife up or down until the knife brushes against the block when it passes above the knife. (The planing knife protrusion can also be adjusted using a magnetic adjuster for the top cutter, item no. 7500-001-0050. See the instructions enclosed with the magnetic adjuster.)

**!** Tighten the lock screws that lock the knife, counter-clockwise. Start by tightening carefully. Move from the sides in move towards the middle, retightening them later.

- ⚠ When the top cutter's bearing housing is adjusted, or when the planing knife's cut is changed, the counter's pre-set must be height calibrated.

#### **ADJUSTMENT OF THE TRAPEZOIDAL THREADED BAR'S CHAIN TRANSMISSION**

The chain, which raises and lowers the table, must not be slack, but needs to be tensioned enough that teeth bite correctly. The tension is set using a nut that is located in the chassis under the planer table on the outfeed side.

- ⚠ Do not touch the chain tension as long as the raising and lowering of the table works, as an incorrect tension could mean that the chain disengages.

## MOLDING KNIFE IN BOTTOM AND TOP CUTTERS

**!** Before you open the safety doors on the planer, ensure that the power is switched off and that the cutters are not rotating. Use protective gloves, particularly when you need to loosen screws that are tightly fastened, or when you are tightening screws (see safety instructions). Beware of the planer knives. It is extremely easy to cut yourself on these, even with the slightest touch.

Molding knives can be assembled in both the top and bottom cutters. Molding knives must always be mounted in pairs – opposite each other. A certain sideways offset of the knife, can however be accepted, as long as the cutter remains balanced.

**!** **WARNING!** Unbalance in the cutter creates vibrations that can damage the planer and cause personal injury.

**!** Molding knives must always be mounted in pairs, so that the cutter remains balanced.

### After assembling the planing knives:

**!** Check that no tools have been left in the planer.

**!** Check that all screws have been sufficiently tightened.

**!** Check that the cutters can rotate freely before the safety doors are closed.

**!** Do you remember the warning instructions on pages 4-5?

### ASSEMBLY

The top and bottom cutter heads have four tooling slots each. As mentioned above, the planer is delivered with two planing knives assembled in two of the tooling slots. In the other two tooling slots, molding knives of different sizes and profiles can be assembled.

**!** On the front edge of the planer/moulder, there is a limiting cover that limits the top cutter's maximum cut when turned. This must be used when molding knives are mounted in the top cutter (196).

- To insert knives into the top or bottom cutter heads, a gib/moulding knife clamp must be used to hold the knife in the head. **Warning:** Do not use any other device to hold moulding knives in these heads!
- Assemble the Gib (D) and molding knife (E) as shown. **Note:** The holes in the bottom of the knife should fit securely on the pins on the gib.
- Lower the gib and molding knife to the side of the cutter where the tooling slots are extended.
- Insert the knife and gib into the groove. Measure the position using the groove in the cutter, and fix by tightening the screw (F) tightly on the back of the gib. (Turning the screw in the Gib as if to loosen it will tighten the Gib into the head.)
- !** The lock screw must not be placed over the area where the tooling slots are extended.
- Measure the position of the knife laterally and assemble an identical knife in exactly the same position on the cutter's opposite side.

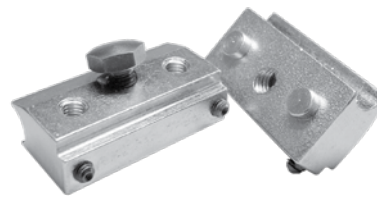

*Knife Gibs for PH360 lower cutter.*



*Knife Gibs for PH360 upper cutter.*

## SIDE CUTTERS

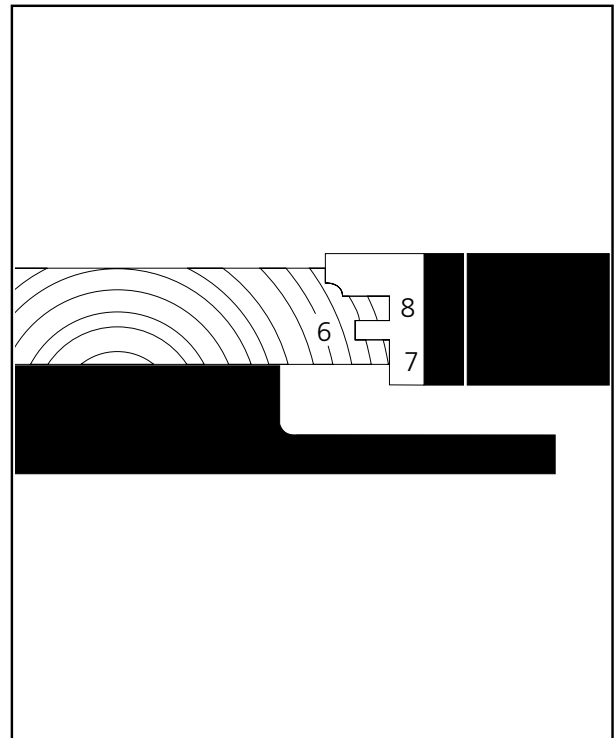
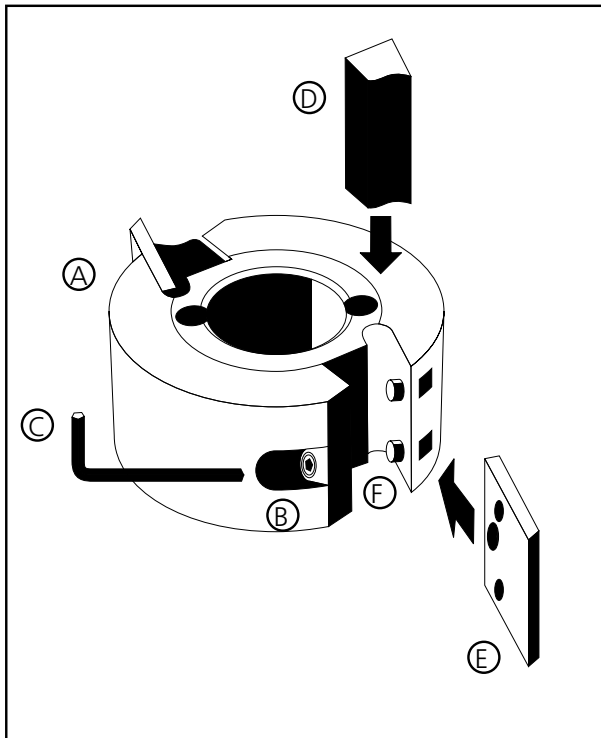

⚠ Before you open the safety doors on the planer, ensure that the power is switched off and that the cutters are not rotating. Use protective gloves, particularly when you need to loosen screws that are tightly fastened, or when you are tightening screws (see warning instructions).

The side cutters are fixed to the planer table. The spindles are 30 mm (1 2/10") in diameter, which is a standard measurement. Upon delivery, the planer is equipped with two universal cutters with planing knives, which you can easily replace with molding knives. For reasons of safety, the cutters work with conventional milling (the workpiece is fed towards the molder's cutting motion). This means that the lock nut and spindle on the moving side cutter must be left-hand threaded.

⚠ The moveable side cutter's lock nut is left-hand threaded.

### After assembling the molding knives:

⚠ Check that no tools have been left in the planer.

⚠ Check that all screws have been sufficiently tightened.

⚠ Check that the cutters can rotate freely before the safety doors are closed.

⚠ Do you remember the warning instructions on pages 4-5?

### DISASSEMBLING

**Cutter 2 (Right, fixed cutters):** Loosen the nut on the spindle with a 30 mm wrench (supplied) and a 1/2" or 13 mm wrench or adjustable wrench. Unscrew the nut and remove the cutter (A) and any spacing rings under the cutter.

**Cutter 3 (left, moveable cutters):** Crank the cutters to their previous position. The nut is loosened in the same way as for cutter 2, with the difference that the nut for cutter 3 is left-hand threaded and is therefore screwed in the opposite direction.

**TIP:** The side cutter nuts are loosened by turning them in the same direction as their respective cutter rotates.

### REPLACING KNIVES

Loosen the lock screw (B) with a 4 mm Allen wrench (C) (supplied) and remove the chip breaker (D). Then remove the knife (E) from the peg (F). Insert a new wrench and tighten the locking screw tightly.



 Ensure that you turn the knives in the right direction (see page 16) when you assemble them in the cutter. The cutting edge must be turned towards the chip breaker. Also check that the cutter is facing the right direction on the spindle. All of the planer/moulder's cutters turn the same way as with conventional milling.

 Check that the non-corrosive spring plate in front of the moveable cutter is not at risk of being bent towards the cutter by the workpiece's unplanned edge. Pay particular attention when cutting workpieces of different widths.

 Ensure that the cutter can rotate freely and that the plate working as a chip barrier behind the moveable cutter is at a distance of approx. 5 mm from the cutter's largest cutting diameter.

### HEIGHT SETTING

The side cutter's height is set by adding or removing the spacers that are supplied in the component package on delivery.

#### Spacer height:

Spacers 40 mm	item no. 7502-001-0038
Spacers 20 mm	item no. 7502-001-0042
Spacers 10 mm	item no. 7502-001-0044
Spacers 5 mm	item no. 7502-001-0046
Schim set (0.1 – 2.0 mm)	item no. 7502-001-0230

To remove the planing knife from the side cutters, loosen the knife's lock screws that are recessed into the cutters. Use a 4 mm Allen Wrench (supplied).

#### The height settings for tongue and grooves:

When tongues and grooves need to be moulded, it is important that these are made opposite one another, i.e. at the same height above the planing table.

- Remove the cutter from the spindle (see above under the Disassembling heading).
- Decide how you want the board to look. E.g. 8 mm above the groove, 6 mm groove and 7 mm under the groove (see image to the left).
- Assemble the molding knife and screw the socket head screws that hold the knife properly.
- Place the cutter on the spindle completely without spacers. Measure the distance from the top edge of the knife down to the planer table.

If the cutter is 40 mm and the groove (6 mm in this example) is in the middle of the knife, the height of the knife above the groove is 17 mm. When the

cutter is pre-set, the height of the knife above the table must be 30 mm ( $7 + 6 + 17 = 30$  mm). If, for example, the height of the knife above the table is measured to 15.2 mm, the cutter must be raised 14.8 mm (0.58") ( $15.2 + 14.8 = 30$  mm).

#### Take the following measures:

- Remove the cutter.
- Combine spacers to the calculated thickness (14.8 mm (0.58") in this example) and thread them onto the spindle.
- Place the cutter on the spindle, screw on the lock nut and tighten properly. Check that the cutter can rotate freely.
- Carry out the points above on the cutter with the tongue knife, so that it is placed at the same height above the table.
- Test-plane a small board, and check that the tongue and groove are at the right height in relation to one another.

Alternatively, the knife can be set arbitrarily, after which a test bit is run. Measure the test bit and correct the knife height.

 Spacers must also be placed above the cutter so that it is fixed on the spindle. Add some of the distance rings that are not used for height setting, so that the thickest ring lies highest and protrudes several millimeters above the lowest threads on the threaded bar. Then screw the nuts on the threaded bar and tighten properly.

### GRINDING

To recover the sharpness of the knife, you can grind the flat side of the knife. Thus retaining the same profile for the pair of knives. Always grind the knives in pairs, so that they have the same weight, otherwise vibrations could occur in the cutter. You can order a grinder from Logosol for sharpening planing and molding knives (Tormek Grinder, item no. 7010-000-1000, Jig for planing knives, item no. 7010-000-1012).

If the profile of the knife is damaged, this should be re-ground by a professional knife sharpener. This is a service that is normally available locally, otherwise contact Logosol.

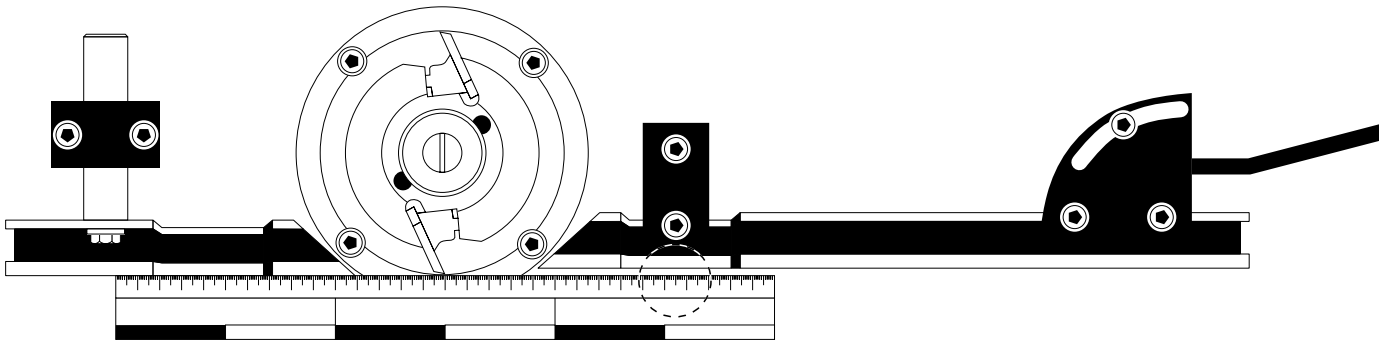

## ADJUSTING THE FENCE BY CUTTER 2

### In general

The front side fence has a double set of holes for assembly. It can therefore be assembled in two basic positions. When the TB90 system is used, the fence will be fitted in the pair of holes on the right, as seen from the infeed side (see assembly of side fence, page 7). When cutters with larger diameters are used, the fence can be moved to the left pair of holes, so that the stroke length is sufficient.

The fixed cutter has two fences, the front (62) and the back fence (54). The front fence controls how much the cutter cuts, and the back fence works as a support for the workpiece when it has passed cutter 2 and is ready to be worked by cutter 3.

Both fences must be in line with one another, but offset in parallel so that the front fence is slightly more to the right (see fig.). In this way, the back fence will support the workpiece once it has been cut by cutter 2 (the workpiece is slightly smaller then).

The fence is fixed by socket head screws in the fence holders (55) according to fig. The screws that lock the fence in the horizontal direction are 13 mm (5/10") hexagonal screws and sit in the fence's U profile. In addition, there are micro adjustments on the fence. When the hexagonal screws are loosened slightly, the knob for micro-adjustments can be turned. If the angle of the fence needs to be adjusted, both the hexagonal and socket head screws must be loosened.

## INSTALLATION OF SIDE FENCES

### Method 1:

- Insert the first fence inwards, for minimal cutting. Add a straight aluminum fence rail tight against the fence. Adjust the fence using the lever until the loose fence rail touches the cutter's plane diameter (the outer rotating line) as it lies against the first fence.

- The plane diameter that is inline with the back fence is where you need to measure to, the cutter's plane diameter that is higher than 30 mm above the table height is unimportant here.
- Align the back fence along the guard rail, which is still tight against the first fence and tighten it. The cut is now 0 mm. The first fence, cutter and back fence are fully inline, and the first fence controls the angle through the machine.
- Remove the fence rail and all loose tools from the machine.
- Move the first fence back to the required cut and lock it using the tie-back knob. (Around 2 mm is usually a suitable cut for the first cutter.)

### Method 2:

- The back fence is pulled in so that it is not used, and is fixed there. (Check that the cutter can rotate freely.)
- Position the front fence so that the required cut depth is obtained and the fence stands straight. Tighten the screws that fix the fence.
- Close the safety doors and take the measures required to start the planer/moulder (see page 4).
- Start the bottom cutter, both side cutters and the feeder and feed in a test piece of approx. 1 meter (3 ft). Stop the planer/moulder just as the board reaches the moveable cutter (cutter 3).
- Drive the back fence towards the planed part of the board.



Installation jig for adjusting fences.

- Check that the test piece is lying against both fences and tighten the back fence's lock screws.

 Check that all screws that fix the fences are properly tightened, and that the cutter can rotate freely.

**TIP:** If there is a problem in that the board does not follow the fences, it could be that the back fence is not at the right level in relation to the cutter, that the fences are not completely parallel to one another, or that the fence does not run straight through the planer/moulder. If it is difficult to get the fence to lie perfectly straight through the planer/moulder, it is better that the fences are slightly angled to the left, towards cutter 3, as the feed rollers will then press the workpiece against the fence. If the fences lie at a slight angle to the right, away from cutter 3, the feed rollers will pull the object away from the fence, which will lead to incorrect measurements and a badly planed surface.

### ADJUSTING THE MOVEABLE CUTTER (CUTTER 3)

Loosen the lock handle (91) that is located on the slide under the table and/or the slotted screw that is located above the slide (38). Then insert the crank (260) onto the threaded rod on the side of the planer and move the side cutter head to the required planing width. One rotation of the crank is 4 mm.

Measure the distance between the cutter knives and the back fence with sliding caliper. This measurement becomes the width of the finished board. Fix this position with the lock handle under the table.

### INDICATOR

The indicator shows the width measurement in mm in black, and 1/10 mm in red. Each time, when setting to a new profile: plane a board, measure the outer measurements with the sliding caliper. Turn the small handle to the right of the indicator so this measurement is shown in the window.

### INSTALLING A PRESSURE ROLLER FOR MOVEABLE CUTTERS

Two pressure rollers are located in front of the moveable cutter, to press the workpiece towards the fence. By adjusting this you can also decide how wide the workpieces fed into the planer/moulder can be. These pressure rollers sit on an arm (77) that is anchored in the moveable cutter's slide, which

means that they move with the cutter when this is adjusted.

To set the pressure rollers, loosen the socket head screws that fix the arm in the moveable cutter's slide with a 6 mm Allen wrench. Adjust the arm so that the press rollers are pressed in by approx. 5 mm when the workpiece is fed into the planer.

A spring plate (supplied on delivery) can be mounted in front of the moveable cutter between the press rollers' arm and screw plate. The spring plate has oval holes that allow adjustment in and out from the workpiece. The spring plate works partly as a tension control, but also as a fence in front of the cutter which reduces the risk of long splinters being knocked out of the workpiece during large cuts.

Adjust the feather plate so that it is pushed in to a couple of millimeters from the unplanned edge of the workpiece.

 Check that there is no risk of the spring plate pushing into the cutter's knife if you are planing an object of variable width. Maintain a safety margin of at least one centimeter in the pressed in position.

After the moveable cutter, there is another pressure roller (76) which pushes the cut workpiece towards the back fence. Set the pressure roller so that it protrudes approx. 1-3 mm from the cutter's smallest plane diameter, at the same height as the pressure roller.

The height of the pressure roller can also be set with washers above or below it. Which may be required for producing certain profiles.

### TEST RUN

Always run a test piece and make subsequent adjustments. Run a piece straight through the planer at the slowest feed speed. Look through the cover while it is being planed and check that the board is lying against the fences in front of and behind cutter 2.

Then measure the profile, its height and width, and subsequently adjust the cutters and the setting for the molding knives if required.

## VARIABLE FEED MOTOR INSTRUCTION

**WARNING!** Do not turn the adjustment knob when the planer/moulder is not running.

### ASSEMBLY (IF THE VARIABLE FEED MOTOR IS ASSEMBLED IN PLACE).

Assemble the feed motor package on the last feed roller. Make sure that the torque stay is in place. Lock this with the central screw on the roller.

### SETTING THE FEED SPEED

Turn the wheel clockwise to increase the speed.

### INDICATOR DIAL FOR THE FEED SPEED

The indicator dial is/must be mounted in the hub of the wheel. It works like an indicator that has a weight in one part, so the indicator moves. The black indicator shows a figure.

The indicator dial has a relative scale. See the numbers as an indicator. The higher the number, the greater the speed.

Start the planer/moulder and turn the wheel so the planer reaches minimum speed.

Remove the indicator dial and turn it so the indicator is set to zero. Then press the indicator dial in with the indicator pointing upwards towards zero.

Use the indicator dial so that you can return to the best speed for the profile you are planing.

#### If you have a 3-15 m/min (10-49 ft/min) gear:

0 on the indicator dial is 3 m/min (10 ft/min)  
8 on the indicator dial is 15 m/min (49 ft/min)

#### If you have a 6-30 m/min (19 1/2-98 ft/min) gear:

0 on the indicator dial is 6 m/min (19 1/2 ft/min)  
8 on the indicator dial is 30 m/min (98 ft/min)

AGIP	BLASIA 32
SHELL	A.T.F DEXRON
ESSO	A.T.F DEXRON
MOBIL	A.T.F 220
CASTROL	DEXTRON II
BP	AUTRAN DX

### MAINTENANCE

Fluid should be visible in the fluid level glass. The level is checked when the planetary gear is not running.

Top up if no fluid is visible in the glass. Use oil for automatic gearboxes according to the table below, or use compatible oil.

The variator is filled with AGIP BLASIA 32 at the factory and does not normally require an oil change during its life.

The worm gear oil does not normally need changing or topping up during the life of the gear.

## MAINTENANCE

The PH360 is easy to maintain as 95% of the planer/moulder is protected against rust. The maintenance required, is mentioned below. Ensure that the power to the planer/moulder is switched off before beginning maintenance.

### **After each work session:**

- Clean chips from the planer/moulder. Also remove any chips from under the planer/moulder.
- Clean any resin off the table. Use mineral spirit if necessary. Lubricate the table with paraffin oil, for example.

### **MAINTAIN AT REGULAR INTERVALS AS FOLLOWS**

Lubricate these areas regularly:

- Feed roller Bushings.
- Sprockets, including top and bottom layers.
- The chain for setting table height.
- The chain driving the feed rollers.
- The two bars that the moveable slide runs on, as well as the slide's trapezoidal thread.
- Cast iron table.

Check that all screws and bolt connections are tightened and that cables and electrical connectors are in good condition.

### **USING OR STORING IN COLD OR DAMP ENVIRONMENTS**

If the planer will be stored in a cold or damp environment over a longer period, all corrosive parts must be treated with a rust inhibitor. Cover the planer.

Water can condense in closed spaces. Check that the motors are dry inside by loosening the draining plugs. Check the control panel box.

## SETTING THE UPPER CHASSIS' PLAN

### FOUNDATIONS

Re-setting the chassis plan requires a serious intervention in the planer. Ensure that this is necessary. The planer is set correctly when leaving the factory, but may have adjusted due to careless transport or serious impact.

### SETTING CUTTERS

1. Loosen the screws to the bearing bracket (4 x M8 on each side)
2. Add a completely level block on the table, directly under the cutter.
3. Turn the crank so the cutter is lifted slightly (make sure the knife does not bite)
4. Lock the screws to the bearing bracket

**Setting only the planing table if, for example, the chain has come loose, or the cutters do not have enough trimming allowance.**

1. Add a completely level block on the table, directly under the cutter.
2. Crank the planing table so the block is at a tangent to the cutter
3. Loosen the chain to the planing table via the chain lock

4. Lift up each threaded sprocket so the cutter is at a tangent to the block along its entire length.
5. Check the measurement of the front and back of the table to the stand, adjust the front or back pair of sprockets
6. Assemble on the chain to the planing table.
7. Before assembly you must check that each threaded rod can be turned by hand.

### ADJUSTING THE TOP CUTTER

The top cutter must sit so that it is parallel with the planer table. This is correctly set in the factory, but can be adjusted due to careless transport or serious impact. This is adjusted in the following way, if necessary:

- Loosen the screws on the bearing housing several turns (4 x M8 on each side).
- Add a completely level block on the table, directly under the cutter.
- Turn the cutter so the block does not press against the planing knife or the keyway.
- Crank the table up so the block lifts the cutter slightly.
- Lock the screws to the bearing bracket

## PLANING TIPS

1. When you have finished planing a profile that you know you will be planing again, feed in a board of approx. 1 m (3 ft) long, then switch off the planer/moulder when this has been fed in. Lower the table and remove the board. Next time the profile needs setting, the board can be used as a template for both cutters and fences. Please also note which shims and knives you used for the test board, as well as the position of the molding knives in the horizontal cutters.
2. You can experiment with adjusting the pressure on the feed rollers yourself. Note the basic set-

tings before you start, so you can always return to them. The springs must normally be tensioned more on the right-hand side, particularly if small objects are planed. The feed rollers must be balanced on the object, and not press more on either side.

3. An increased directional function can be achieved if the first feed roller is set with a lighter pressure.

# LOGOSOL PH260 Four-sided planer/moulder

## Produce mouldings, joists and decking with carefully selected knives

Starter package with knives for the planer/moulders PH260, PH360 & PH365



**You can do all this and much more with the starter package!**

**The package includes:** 14 pairs of moulding knives of HSS and 3 pairs of gibs.

The starter package of moulding knives enables you to produce a wide range of profiles. Look at the examples of knife combinations to the right. Let the examples of wood profiles inspire you, but you can do a lot more with the starter package!

*With the PH360 comes an other type of knife gibs for the top cutter.*

**Starter package with moulding knives and gibs for the PH260**

TB90-009 **7.390,-**

**Starter package with moulding knives and gibs for the PH360/PH365**

TB90-008 **8.690,-**

### Examples of wood profiles you can make with the knives in the starter package



#### SKIRTING BOARDS

Included in the starter package!

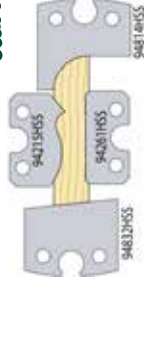

Rustic style  
Plain skirting board 1  
Plain skirting board 2  
Plain skirting board 3



#### PANELLING

Included in the starter package!

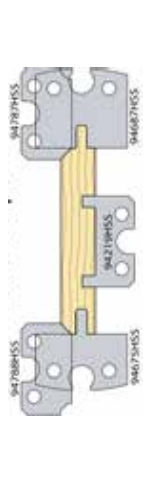

Open bevelled T&G  
Close rounded T&G  
Open rounded T&G  
Plain T&G



#### CORNICES

Included in the starter package!

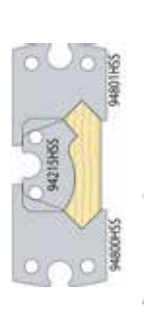

Rustic style cornice  
Plain cornice

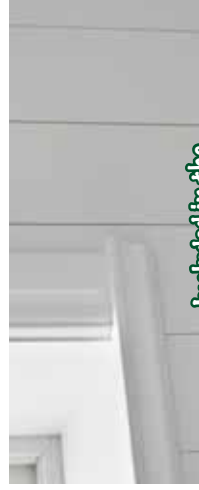

#### CASINGS

Included in the starter package!

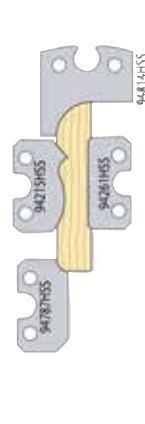

Rustic style casing  
Plain casing 1  
Plain casing 2  
Plain casing 3



#### WAINSCOT MOULDINGS

Included in the starter package!

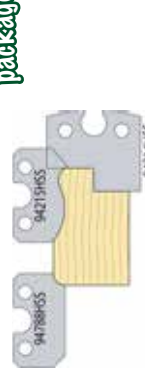

Bevelled edge  
Rustic style  
Rounded edge



Included in the starter package!

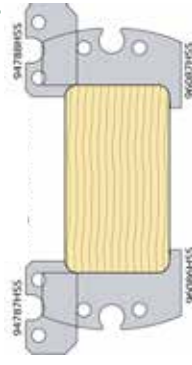

Produce joists and decking of different dimensions.  
Width (PH260): Up to 260 mm. Width (PH360): Up to 360 mm.  
Height: Up to 60 mm.

BASIC PACKAGE PH360 ITEM NO: TB90-008

14 pairs of moulding knives of HSS + 4 pairs of knife gibs for making:

- Casing
- Rounded T&G
- Bevelled T&G
- Wainscot moulding
- Cornice
- Skirting board
- Joists & Decking

TOP CUTTER  
KNIFE GIB -038 X3

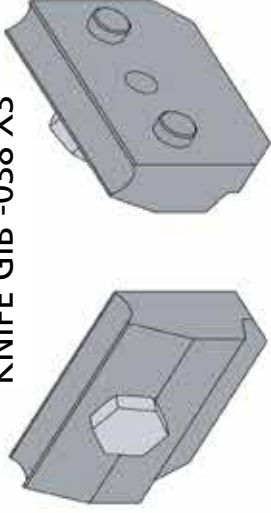

BOTTOM CUTTER  
KNIFE GIB -038 X1

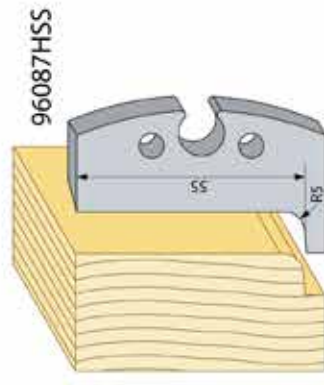
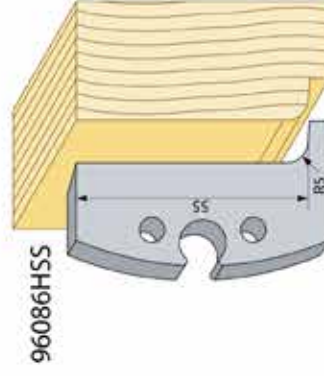
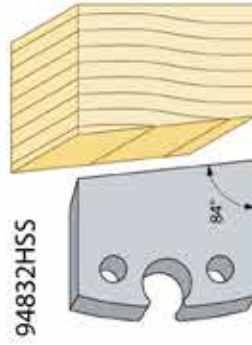
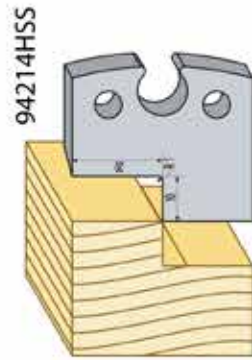
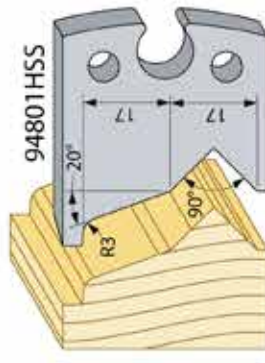
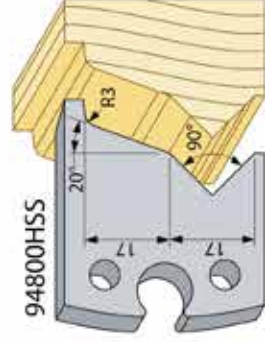
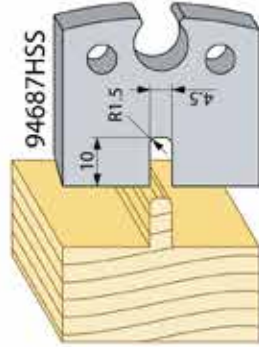
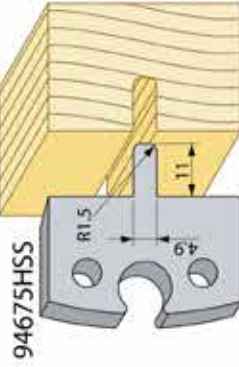
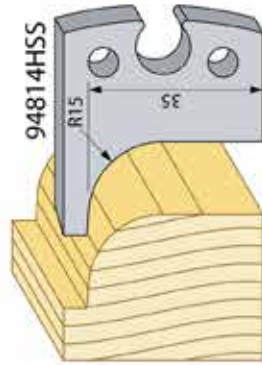
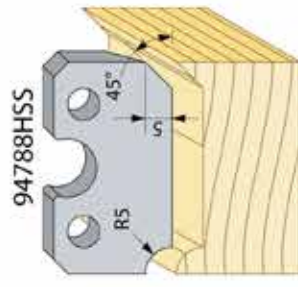
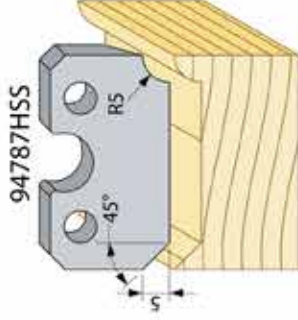
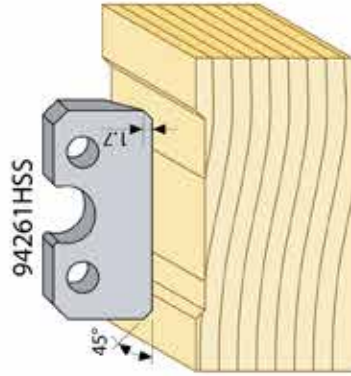
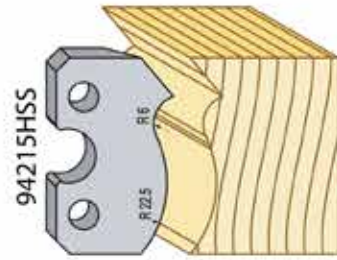
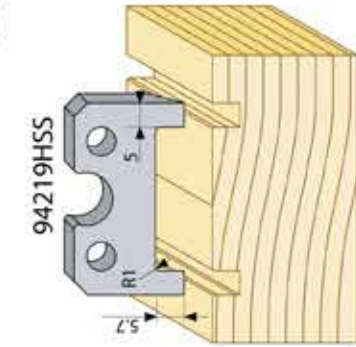
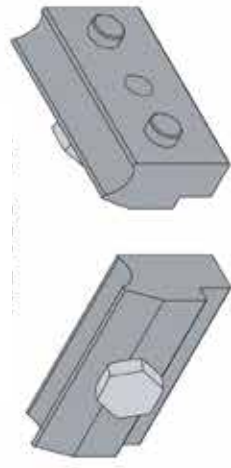



# Knife mounting in the LOGOSOL PH360

Plain T&G

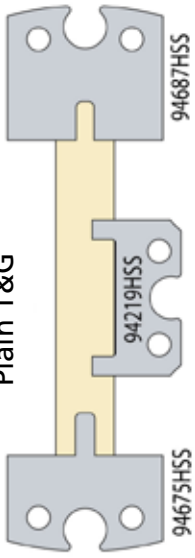

94788HSS

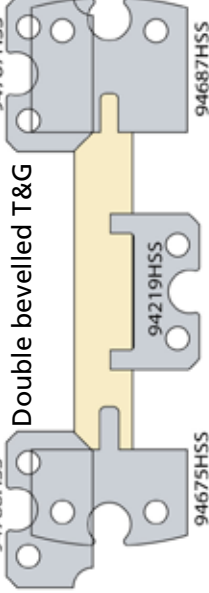

Double bevelled T&G (open)

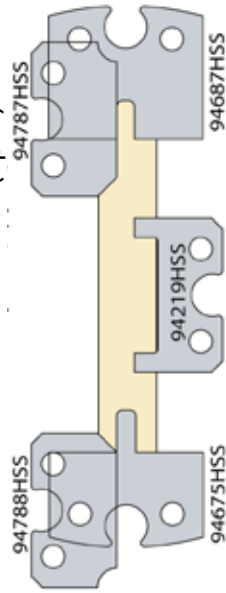

Double rounded T&G

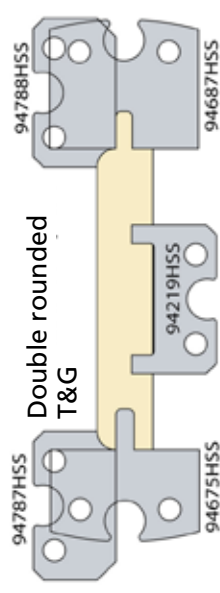

Double rounded T&G (open)

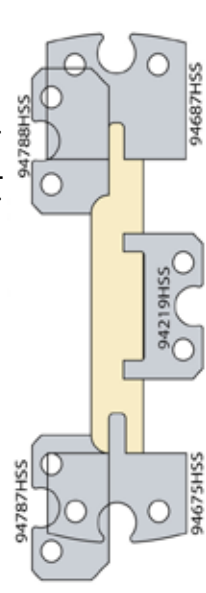

Plain casing 1

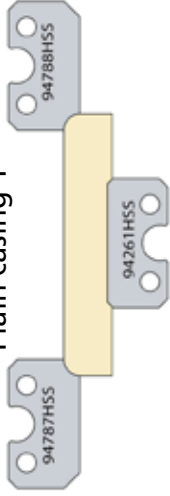

Plain skirting board 1

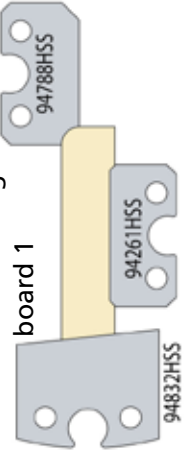

Plain casing 2

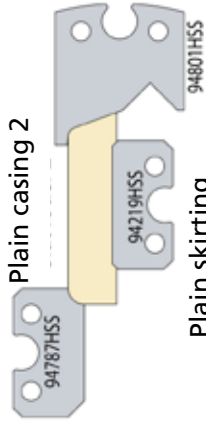

Plain skirting board 2

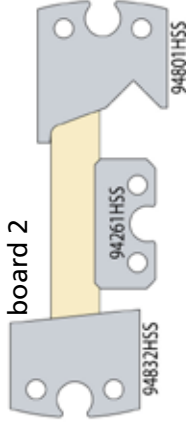

Rounded casing

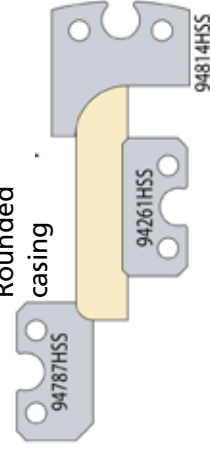

Rounded skirting board

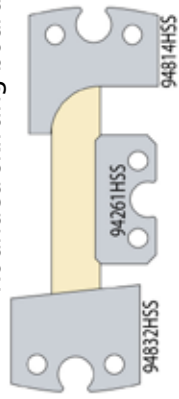

Plain cornice

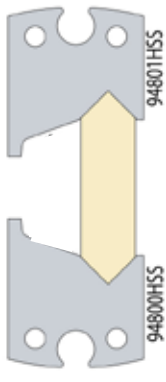

Swan neck cornice

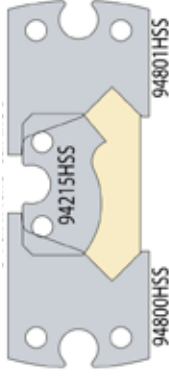

Wainscot moulding, Swan neck

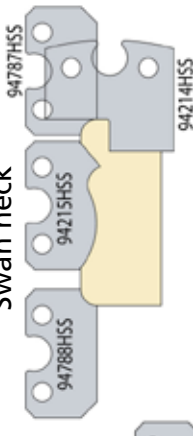

Rustic style casing

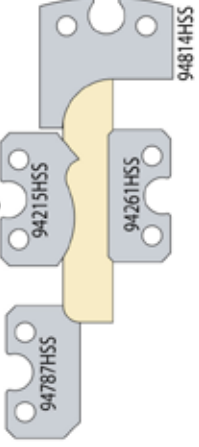

Rustic style skirting board

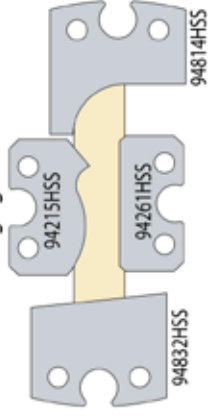

Joists & decking

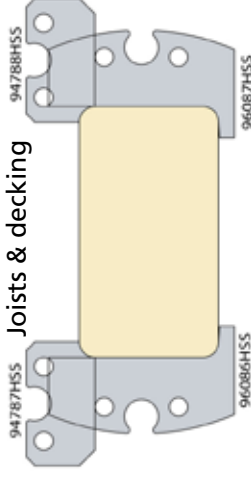

Wainscot moulding, rounded

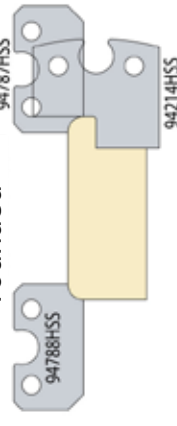

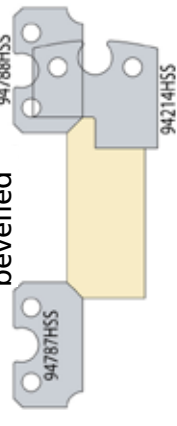

Wainscot moulding, bevelled



## ELECTRICAL SCHEMATIC

### ELECTRICAL SCHEMATIC 230 V 3-PHASE (50 Hz)

-  Lethal voltage. Incorrect connection is potentially fatal.
-  Note that you need authorization to open or intervene in the electrical equipment.
-  Ensure that the power supply is switched off before you open the system.

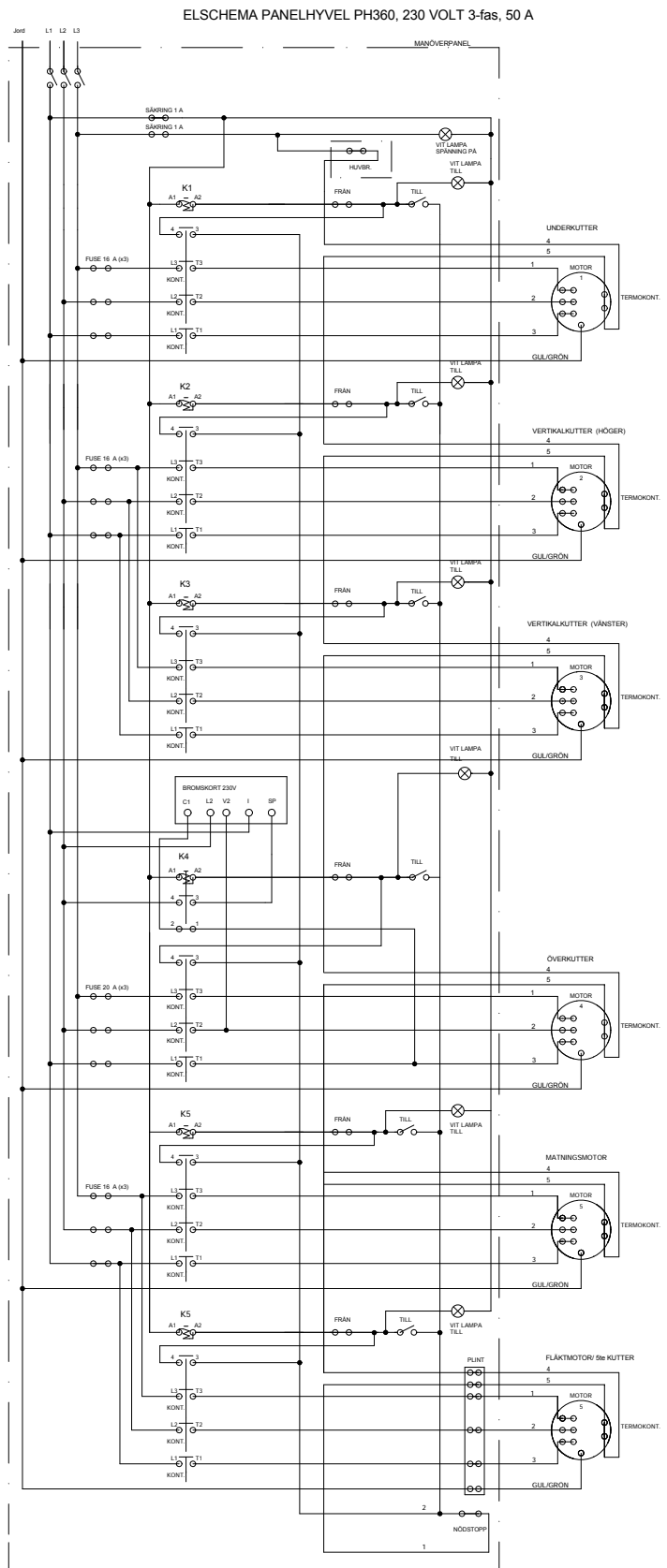

## ELECTRICAL SCHEMATIC 230 V 3-PHASE (60 Hz)



Lethal voltage. Incorrect connection is potentially fatal.



Note that you need authorization to open or intervene in the electrical equipment.



Ensure that the power supply is switched off before you open the system.

ELECTRICAL DRAWING PH360, 230 VOLT 3-PHASE, 50 A

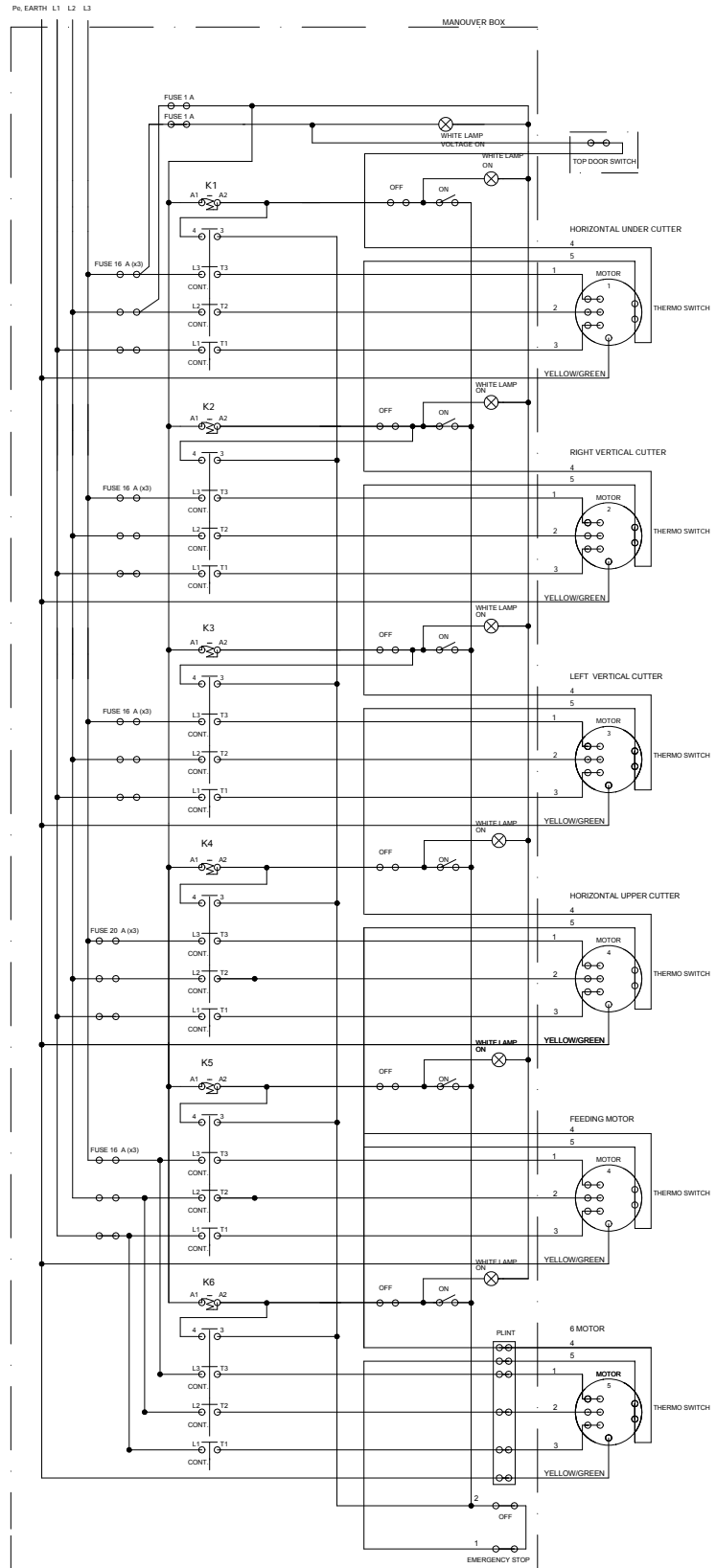

## ELECTRICAL SCHEMATIC 400 V 3-PHASE



Lethal voltage. Incorrect connection is potentially fatal.



Note that you need authorization to open or intervene in the electrical equipment.



Ensure that the power supply is switched off before you open the system.

ELSCHEMA PANELHYVEL PH360, 400 VOLT 3-fas, 32 A

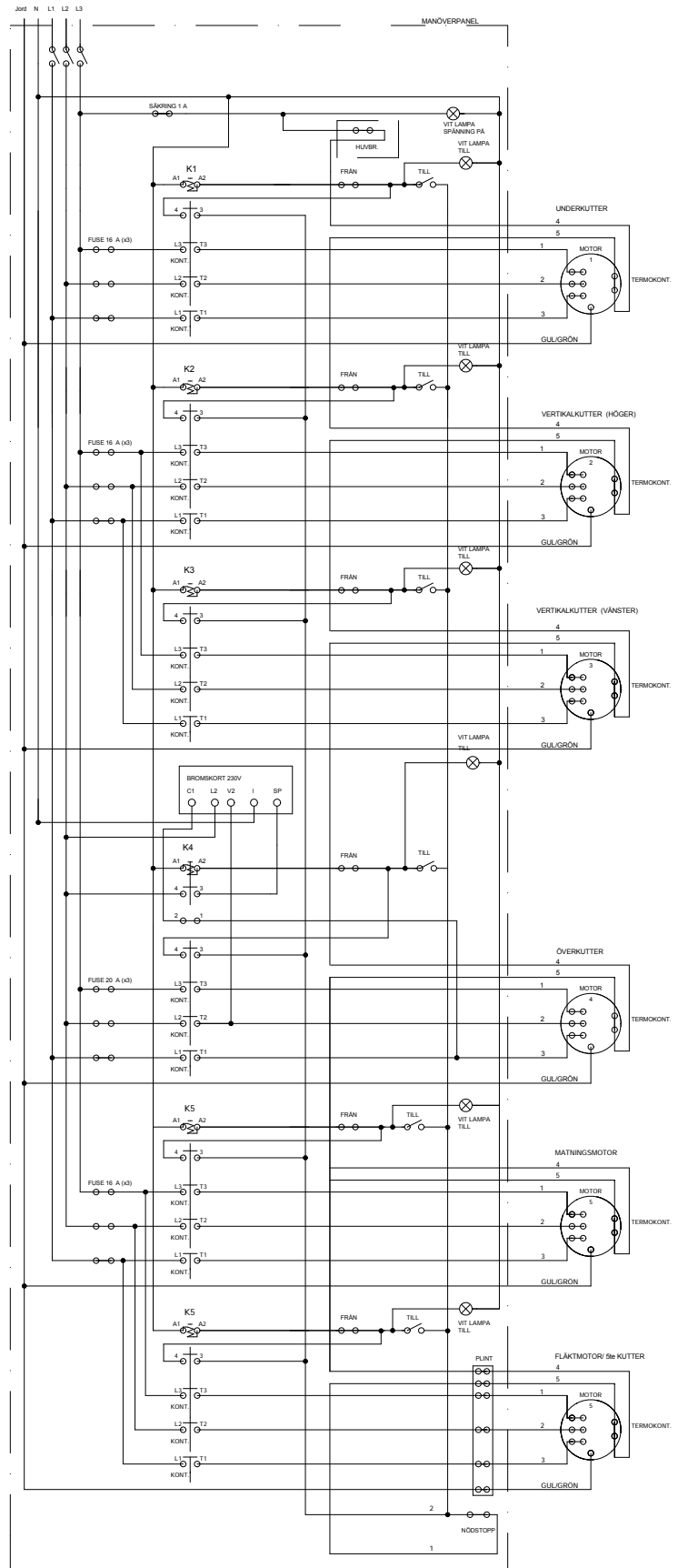

## TECHNICAL DATA

<b>PH360</b>	
Length and width:	2,970 x 1,125 mm (117" x 44")
Height	1,430 mm (56")
Weight	600 kg (1322 2/10 lbs)
<b>4-SIDED MOLDING</b>	
Width	360 mm (14")
Height	10-130 mm (4/10"-5")
<b>2-SIDED MOLDING</b>	
Width	410 mm (16")
Height	10-230 mm (4/10"-9")
<b>PLANING</b> (assembly required)	
Width	510 mm (20")
Height	230 mm (9")
<b>TOP HORIZONTAL CUTTER</b>	
Diameter	88 mm (3 5/10")
Width	510 mm (20")
Output	5.5 kW (7.5 Hp)
Rotational speed	6,000 rpm
Cut when planing:	0-8 mm (0-3/10")
Cut when molding	Max. 20 mm (8/10")
<b>BOTTOM HORIZONTAL CUTTER</b>	
Diameter	72 mm (2 8/10")
Width	410 mm (16")
Output	4 kW (5.5Hp)
Rotational speed	6,000 rpm
Cut when planing:	0-8 mm (0-3/10")
Cut when molding	Max. 10 mm (4/10") (Slot milling: 15 mm 6/10")
<b>SIDE CUTTERS</b>	
Diameter of spindle axel	30 mm (1 2/10")
Cutter height	Max. 130 mm (5")
Diameter	Max. 140 mm (5 5/10")
Output	3 kW (Hp)
Rotational speed of side cutters	6,000 rpm
Cutting depth	Max. 30 mm (1 2/10")
<b>SUPPLIED SIDECUTTERS</b>	
Type and quantity	2 x TB90
Diameter, body	90 mm (3 5/10")
Height, body	40 mm (1 6/10")
Cut, type and width	Planing knife HSS, 50 mm (2")
<b>FEED, PLANED VARIATOR</b>	
Output	0.75 kW (1 Hp)
Feed rate	3-15 m/min or 6-30 m/min (10-49 ft/min or 19 1/2-98 ft/min)
<b>ELECTRIC SYSTEM</b>	
Total output	16.25 kW (22 hp) All motors are equipped with overheating protection.
Electrical connection	3-phase, 400 V, 32 A, 20A fuses are sufficient for less demanding production.

## LIST OF COMPONENTS

Pos.	Description	Quantity	Ref. no.	Pos.	Description	Quantity	Ref. no.
1	Cast Iron Table	1	7536-001-0001	57	Belt Pulley motor,		
2	Plastic Slide Strip,			Bottom Cutter	1	7502-001-0154	
	Feed Rollers	2	7536-001-0002	60	Moulding Knife,		
3	Plastic Slide Strip,			410 mm	2	7000-002-8410	
	Top Cutter	1	7536-001-0003	61	Chip Breaker,		
8	Chip Duct,			410 mm	2	7502-001-0140	
	Bottom Cutter	1	7536-001-0008	67	Poly-V Beltv, Bottom		
14	Motor,			Cutter, 8 tracks	1	7500-001-2007	
	Bottom Cutter	1	7502-001-2340	70	Bronze Bushing,		
14	Motor, Bottom			Slide	1	7536-001-0070	
	cutter, USA	1	7502-001-2606	74	Slide	1	7502-001-0062
21	Belt Pulley,			76	Pressure Roller,		
	Bottom Cutter	1	7502-001-0300	complete	1	7502-001-0178	
26	Belt Pulley, Bottom +			77	L Bracket, Complete	1	7536-001-1077
	Side Cutter	2	7502-001-0154	78	Pressure Roller,		
27	Poly-V Belt, Side			Front/Back, Compl.	3	7536-001-1084	
	Cutter, 8 tracks	2	7500-001-2005	90	Bracket, L Bracket	1	7502-001-0213
28	Motor, Side Cutter			90B	Lock Fitting,		
	400/230V	2	7502-001-0350	L Bracket	1	7502-001-0212	
28	Motor, Side Cutter,			91	Locking Handle,		
	USA	2	7502-001-0605	Adjustable, M8x20	1	7536-001-0091	
29R	Spindle, Cutter 1R	1	7536-001-029R	94A	Chip Duct,		
29L	Spindle, Cutter 1L	1	7536-001-029L	Fixed Cutter	1	7536-001-094A	
29L+R	Ball Bearing, Side			94B	Chip Duct,		
	Cutter, Top Bearing	2	7502-001-0052	Movable Cutter	1	7536-001-094B	
29L+R	Ball Bearing, Side Cutter,			108	Cover Plate,		
	Bottom Bearing	2	7502-001-0152	Metre Counter	1	7536-001-0108	
30	Universal Cutter,			109A	Digital Counter,		
	TB9092, 2 knives	2	7000-000-9092	Side Cutter	1	7536-001-109A	
31R	Nut, Spindle 1 R	1	7502-001-0010	109B	Metre Counter,		
31L	Nut, Spindle 2 L	1	7502-001-0030	Height Adjustment	1	7536-001-109B	
32	Spacer 5 mm	2	7502-001-0046	109C	Inch Counter, USA	1	7536-001-109C
32	Spacer 10 mm	2	7502-001-0044	109D	Inch Counter, USA	1	7536-001-109D
32	Spacer 20 mm	2	7502-001-0042	122	Chain 1, Feed	1	7536-001-0122
32	Spacer 40 mm	2	7502-001-0038	123	Chain Sprocket,		
34	Fence 2	1	7536-001-0034	Rollers	8	7536-001-0123	
35	Fence Bracket	2	7502-001-0098	124	Chain M1, M2	1	7502-001-0180
36	Micro Adjustment,			125	Chain 3, Feed	1	7536-001-0125
	Side fence	2	7502-001-0080	126	Chain 4, Feed	1	7536-001-0126
37	Chip Guard Plate	1	7536-001-0037	128	Top Cutter	1	7536-001-0128
38	Locking Screw, Slide	1	7536-001-0038	129	Bearing, Top Cutter	2	7502-001-0052
52	Lock Handle, adjustable			130	Bearing Bracket,		
	M10 Inv. Thread	2	7536-001-0052	Top Cutter,	2	7536-001-0130	
54	Bottom Cutter	1	7536-001-0054	130	O-Ring, Top Cutter	2	7536-001-0716
55	Ball Bearing,			131	Belt Pulley, Top Cutter		
	Bottom Cutter	2	7502-001-0152	Spindle	1	7536-001-0131	
56	Bearing Bracket,			133	Moulding Knife 510mm,		
	Bottom Cutter	2	7502-001-0146	HSS, 510x25x3 mm	2	7000-002-8510	
56	Seal O-ring,			134	Chip Breaker,		
	Bottom Cutter	2	7502-001-0120	510 mm	2	7536-001-0134	

<b>Pos.</b>	<b>Description</b>	<b>Quantity</b>	<b>Ref. no.</b>	<b>Pos.</b>	<b>Description</b>	<b>Quantity</b>	<b>Ref. no.</b>
138	Bearing Housing, Rollers, Complete	8	7536-001-1138	185	Motor, Feed, USA	1	7502-001-2193
139	Bronze Bushing, Feed Rollers	14	7536-001-0139	187	Cover, Worm Gear	1	7536-001-0187
143	Feed Roller, Grooved	4	7536-001-0143	189	Crank, Height Setting	1	7536-001-0189
144A	Polyurethane Feed Roller	1	7536-001-0144	193	Chain Tensioning Arm	3	7536-001-0193
144B	Shear Pin, Rubber Roller	1	7502-001-0073	194	Chain Tensioning Wheel	3	7536-001-0194
148	Motor, Top Cutter, 5.5 KW / 7,5hp	1	7536-001-0148	196	Stop Plate on In-Feed side	1	7536-001-0196
148	Motor, Top Cutter, USA 5.5 KW / 7.5hp	1	7536-001-2148	197	Mount, Plastic Cover, Back	1	7536-001-0197
149	Belt Pulley, Motor, Top Cutter	1	7536-001-0149	198	Plastic Cover, Back, Complete	1	7536-001-0198
149	Belt Pulley, Motor, USA Top Cutter	1	7536-001-2149	201	Chain Guard Plate	1	7536-001-0201
152	Poly-V Belt, Top Cutter	1	7536-001-0152	211	Height Setting Handle, Feed Table	1	7536-001-0211
153	Chain, Height Adjustment	1	7536-001-0153	212	In-Feed Table	1	7536-001-0212
154	Trapezoidal Thread Bar for Crank, Table	1	7536-001-0154	216	Adjusting Handle, Fence	1	7536-001-0216
155	Chain Sprocket	4	7536-001-0155	220	Fence 1	1	7536-001-0220
156	Bearing Washer, Top/Bottom	8	7536-001-0156	223	Locking Handle, Adjustable, M10x20	6	7536-001-0223
157	Bronze Bushing, Bearing Washer, Top/Bottom	8	7536-001-0157	224	Locking Handle, Adjustable, M8x25	6	7536-001-0224
163	Trapezoidal Thread Bar, Table	3	7536-001-0163	225	Locking Handle, Adjustable, M10x40	2	7536-001-0225
165	Reinforcement Plate, Top Cutter	1	7536-001-0165	232	Electrical Distribution Box, Compl.	1	7536-001-1232
174	Cover Plate, Slide	1	7536-001-0174	232	Electrical Distribution Box, USA, Compl	1	7536-001-2232
179	Circuit Breaker	1	7536-001-0179	253	Out-Feed Table	1	7536-001-0253
180	Oversize Preventer	1	7502-001-0007	259	Trapezoidal Thread Bar Extender, Slide	1	7536-001-0259
181	Infinitely Variable Feed, Complete	1	7536-001-1184	260	Crank, Side Cutter, Complete	1	7536-001-0260
181	Infinitely Variable Feed, USA, Compl.	1	7536-001-2184	267	Locking Knob, Door	1	7536-001-0267
182	Worm Gear	1	7502-001-1470	268	Cover Plate, Chip Duct	1	7536-001-0268
184	Planetary Gear	1	7502-001-0430	269	Handle, Cover	1	7536-001-0269
184B	Adjustment Knob, Feed	1	7502-001-1197	272	Chip Duct, Top Cutter	1	7536-001-0272
185	Motor, Feed 400/230V	1	7502-001-0193				

## OVERVIEW IMAGES

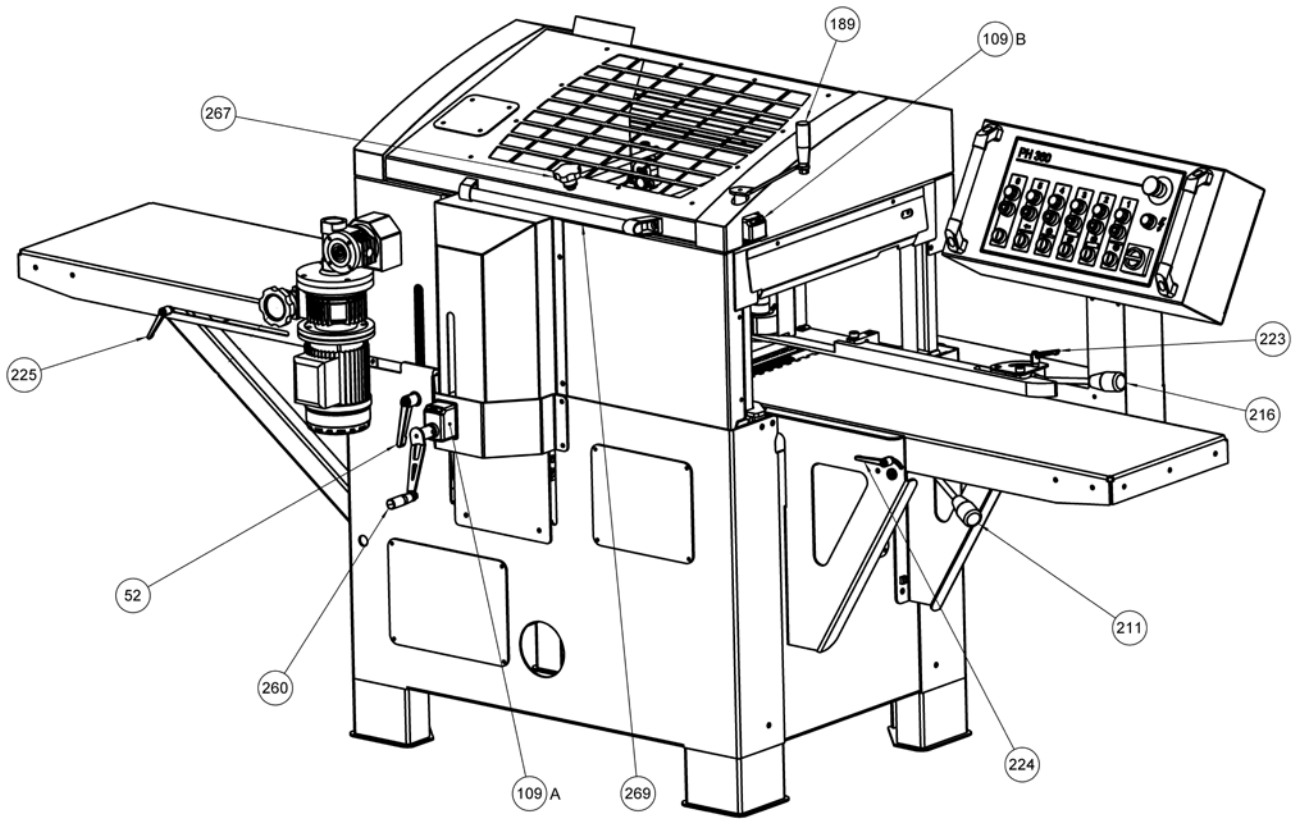

### USA Model

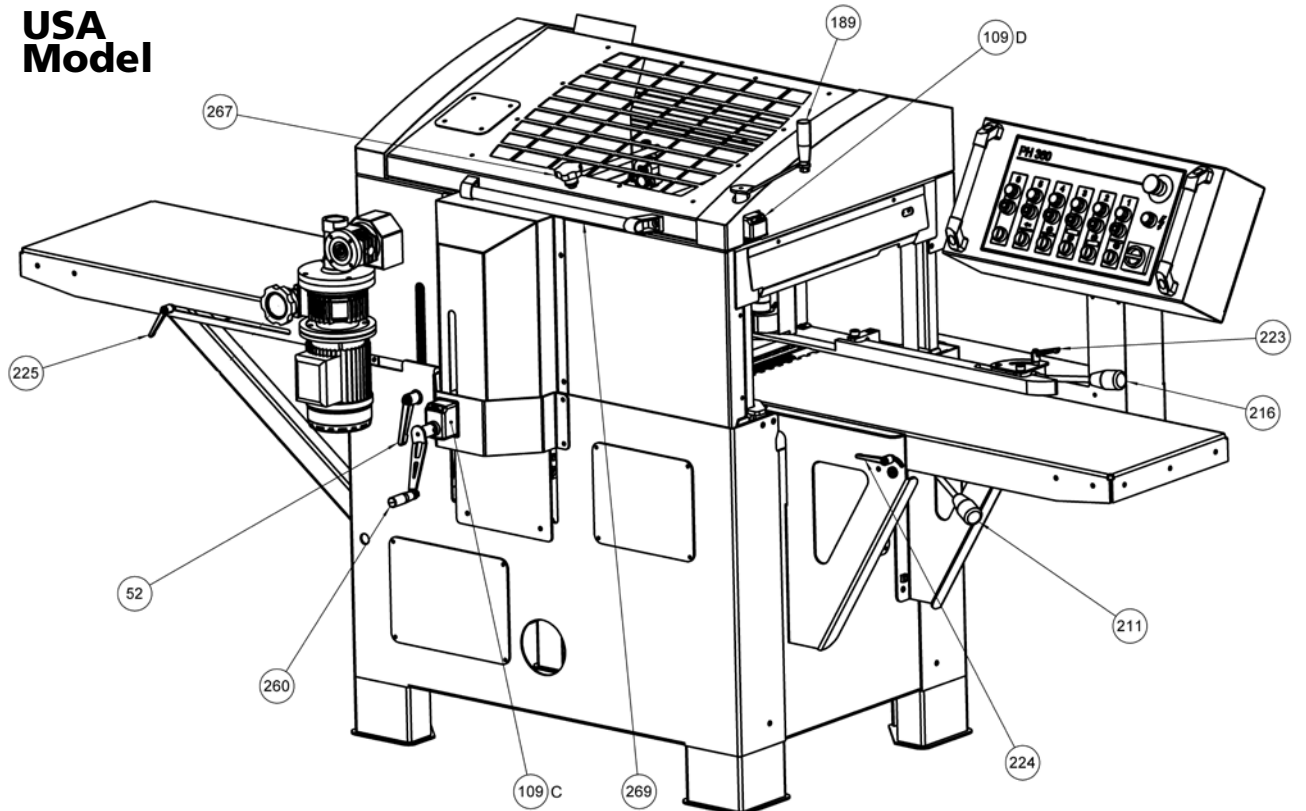



**FRONT**

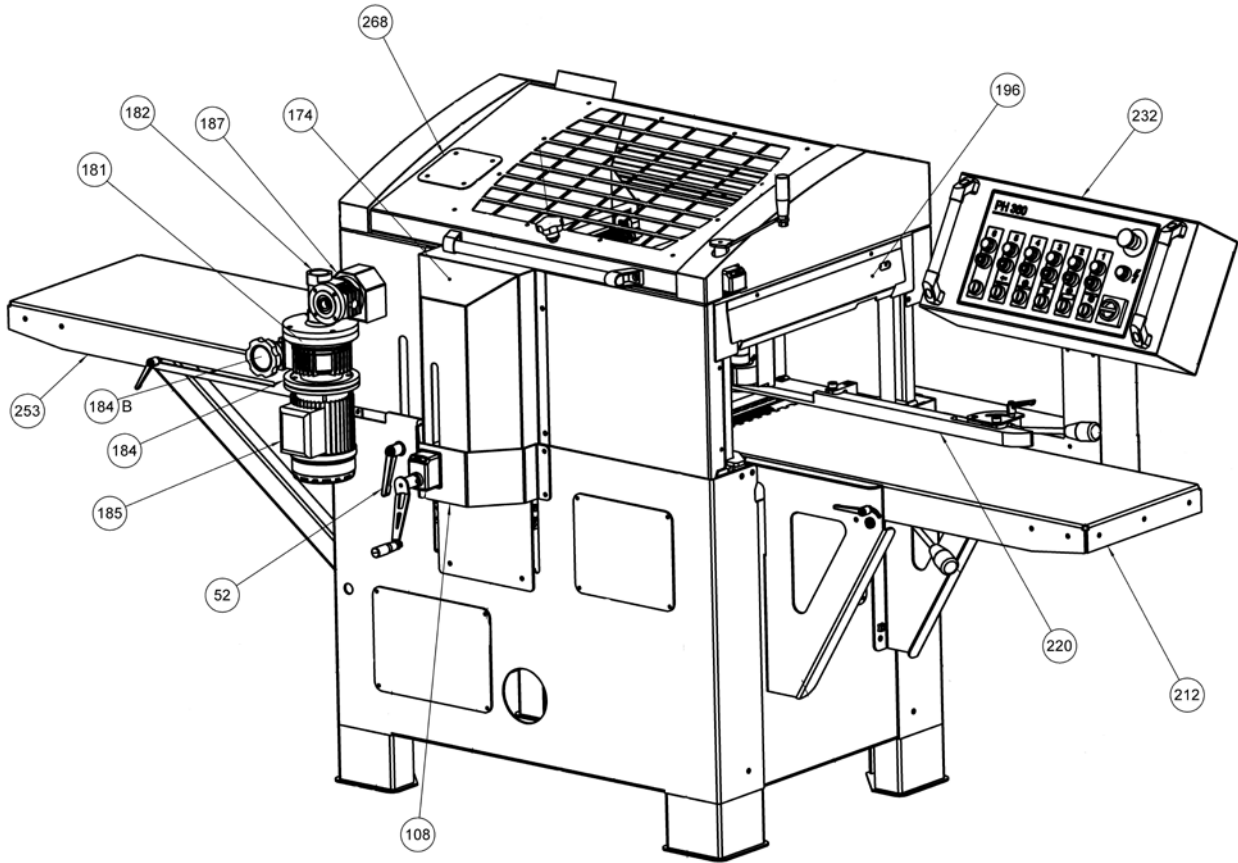

## CROSS-SECTION FRONT

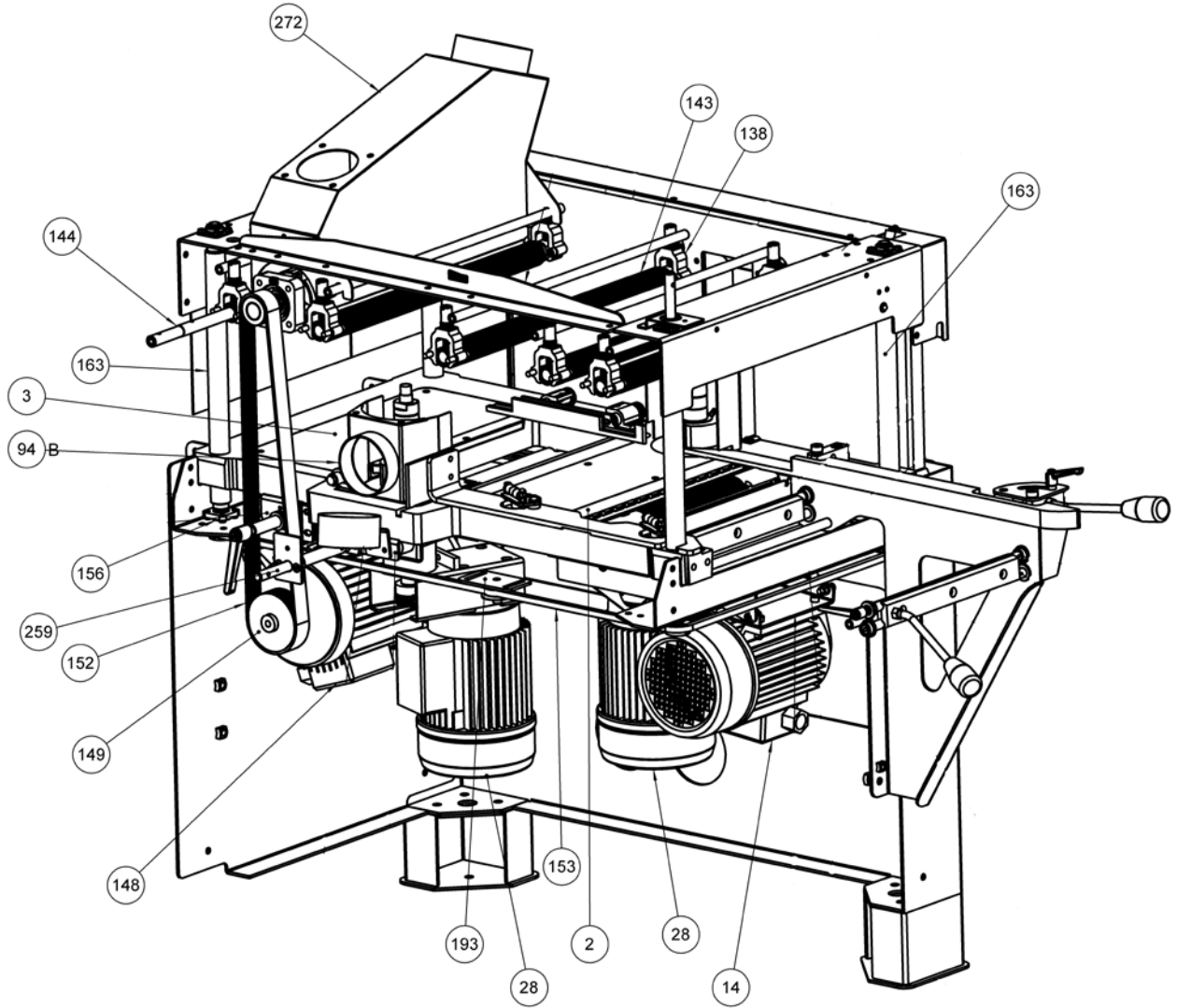

**BACK**

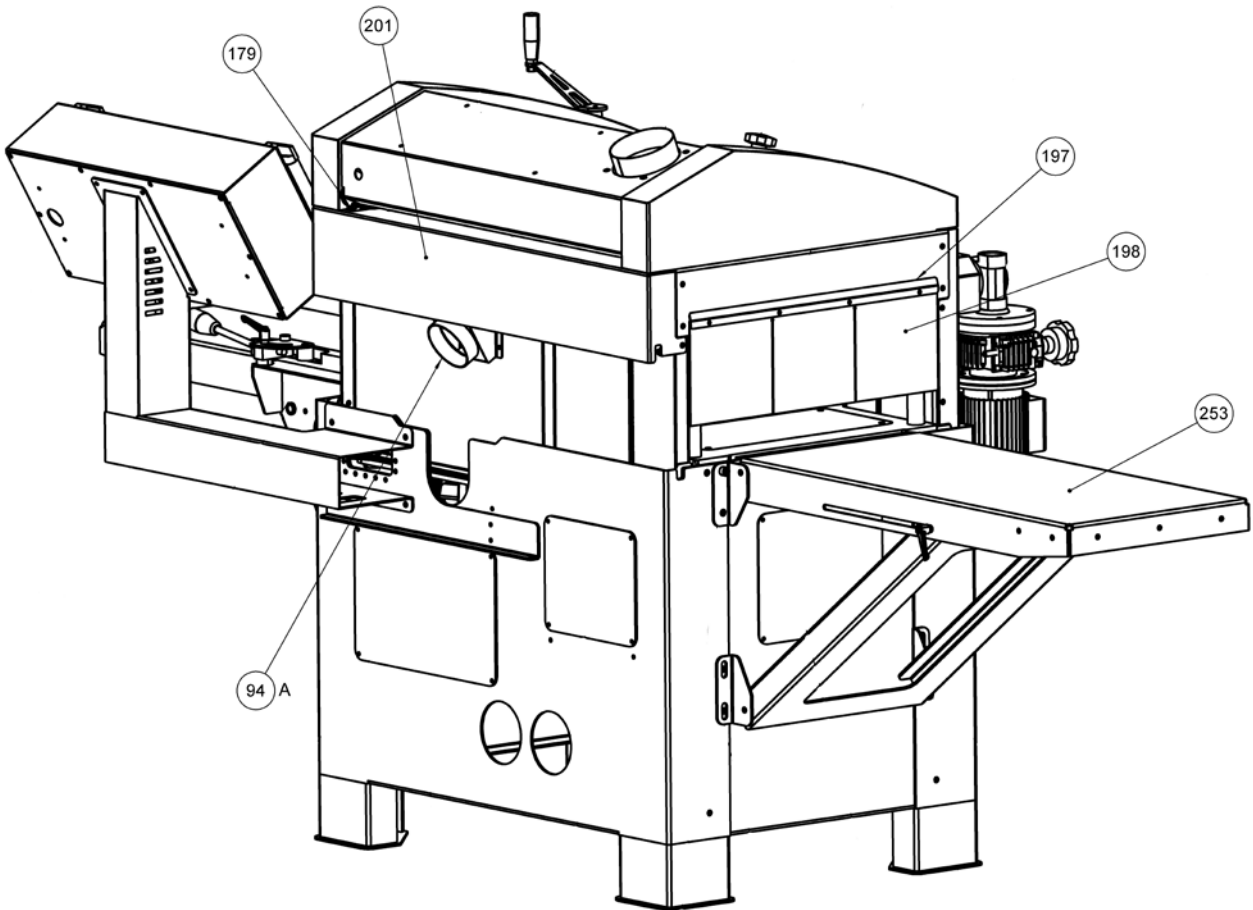

## CROSS-SECTION BACK

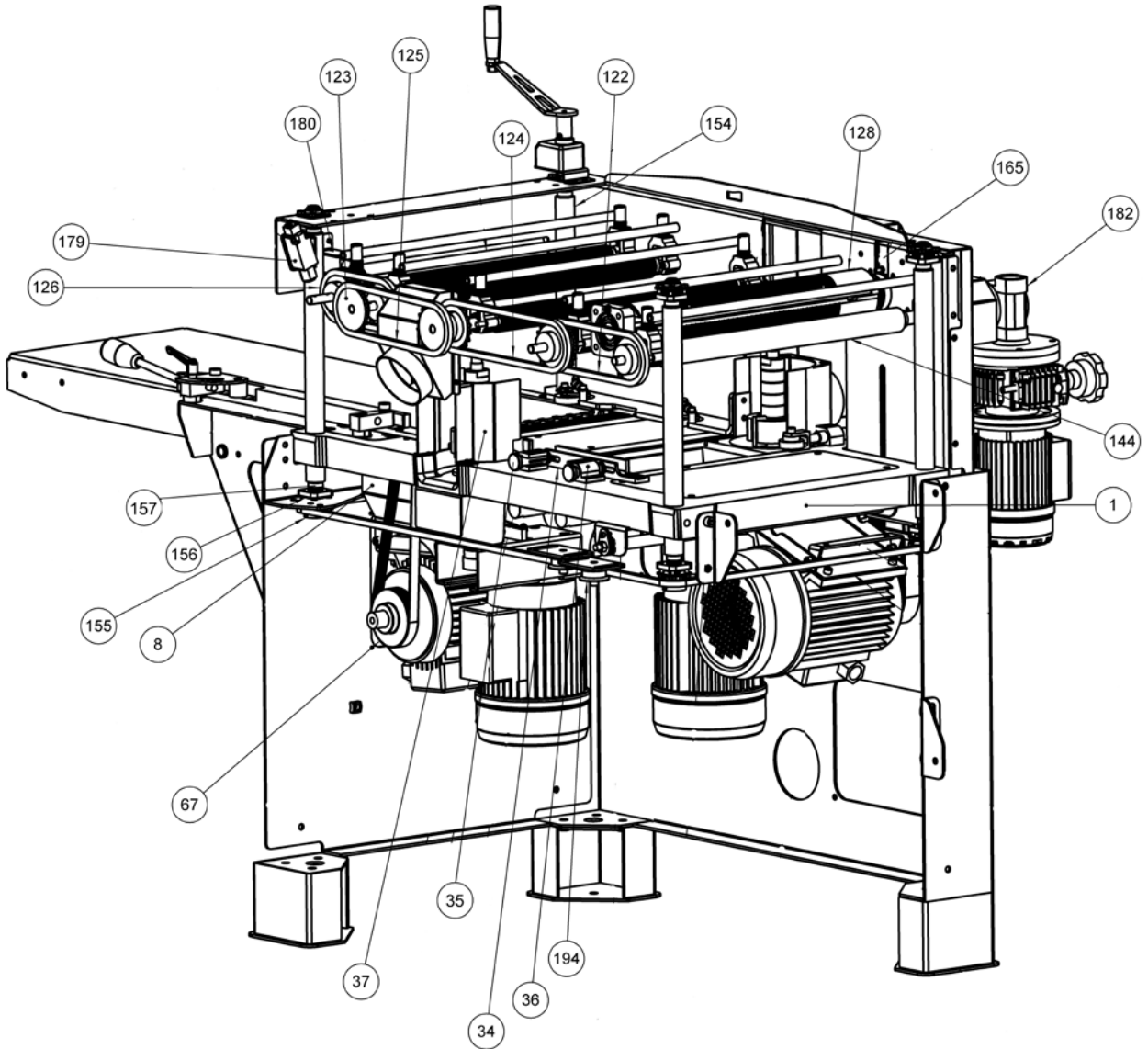

**SKIDS WITH SLIDE**

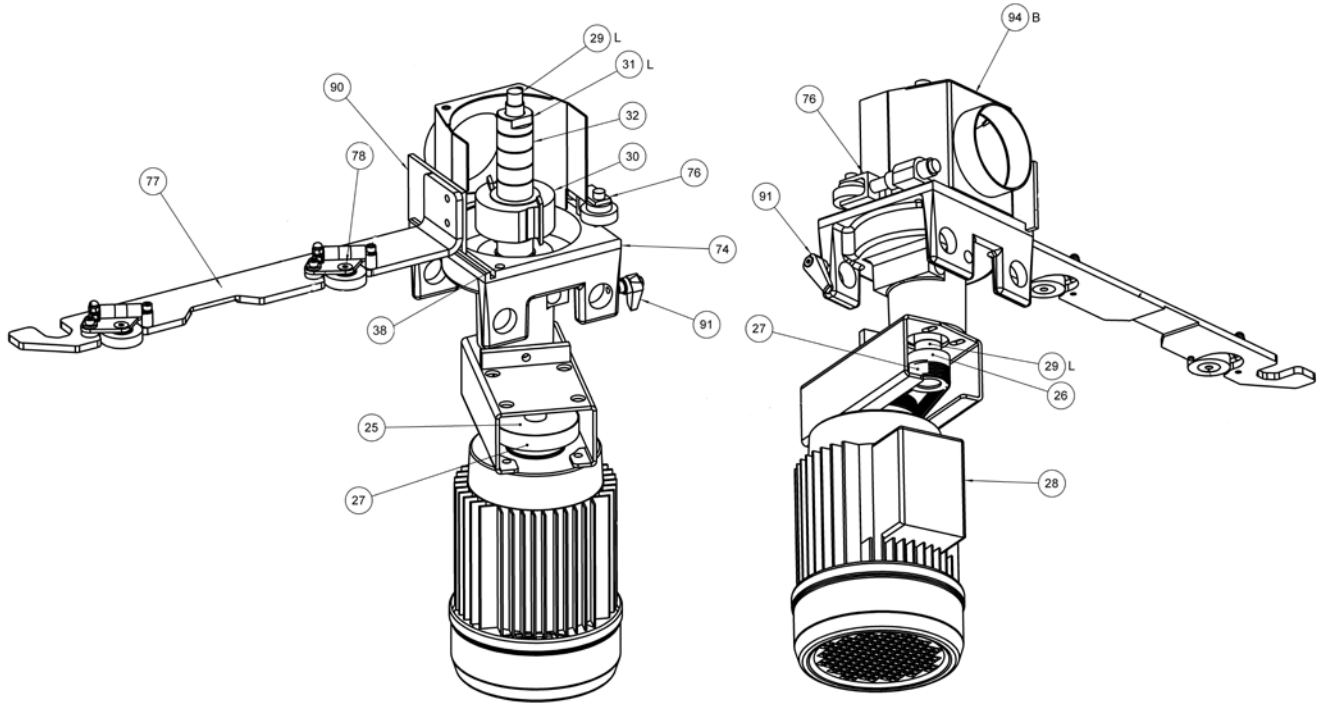

**BOTTOM CUTTERS, FIXED SIDE CUTTERS, CONTROL FOR MOVEABLE CUTTERS, LOCK PLANING TABLE**

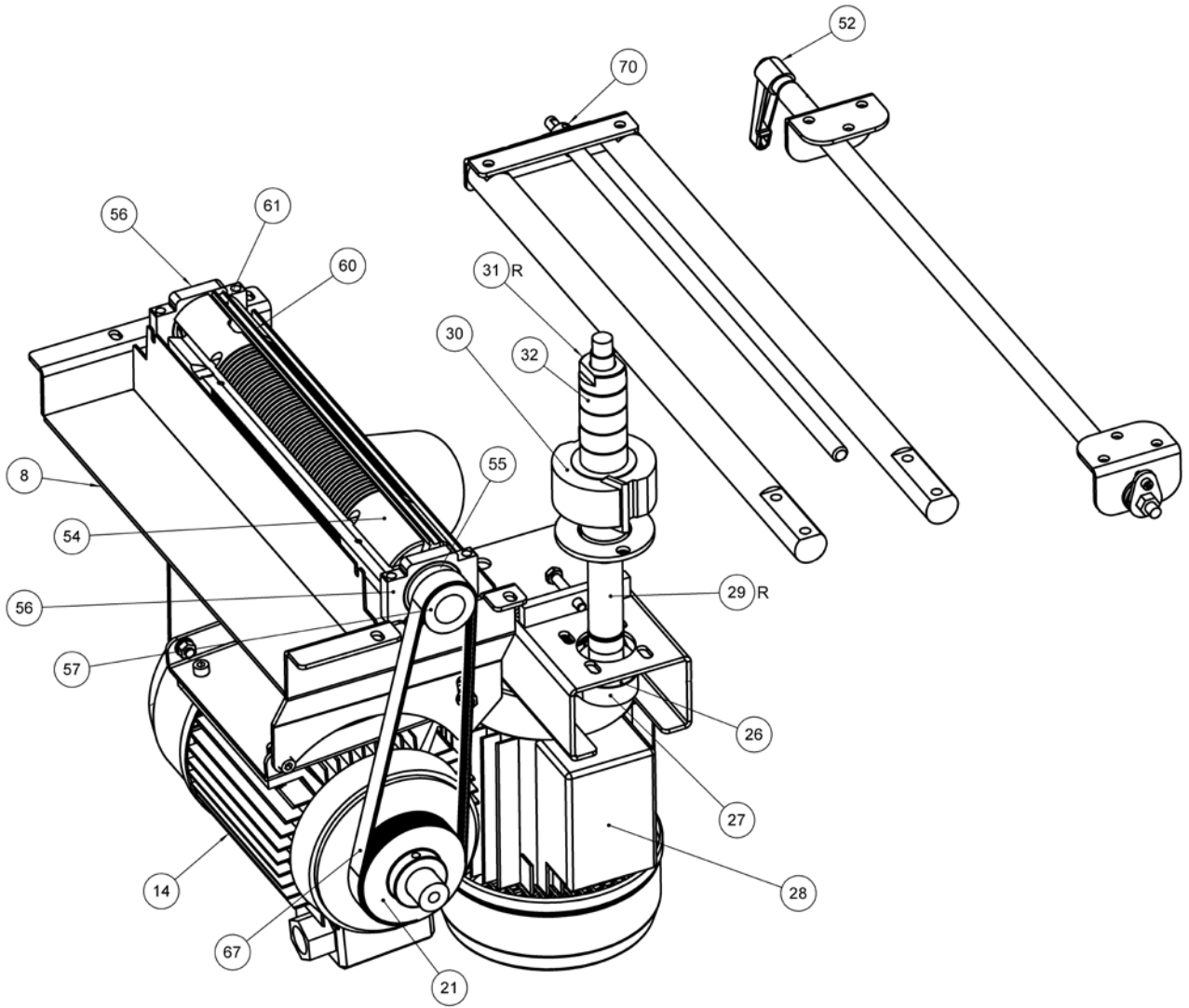

TOP CUTTER, FEED ROLLERS

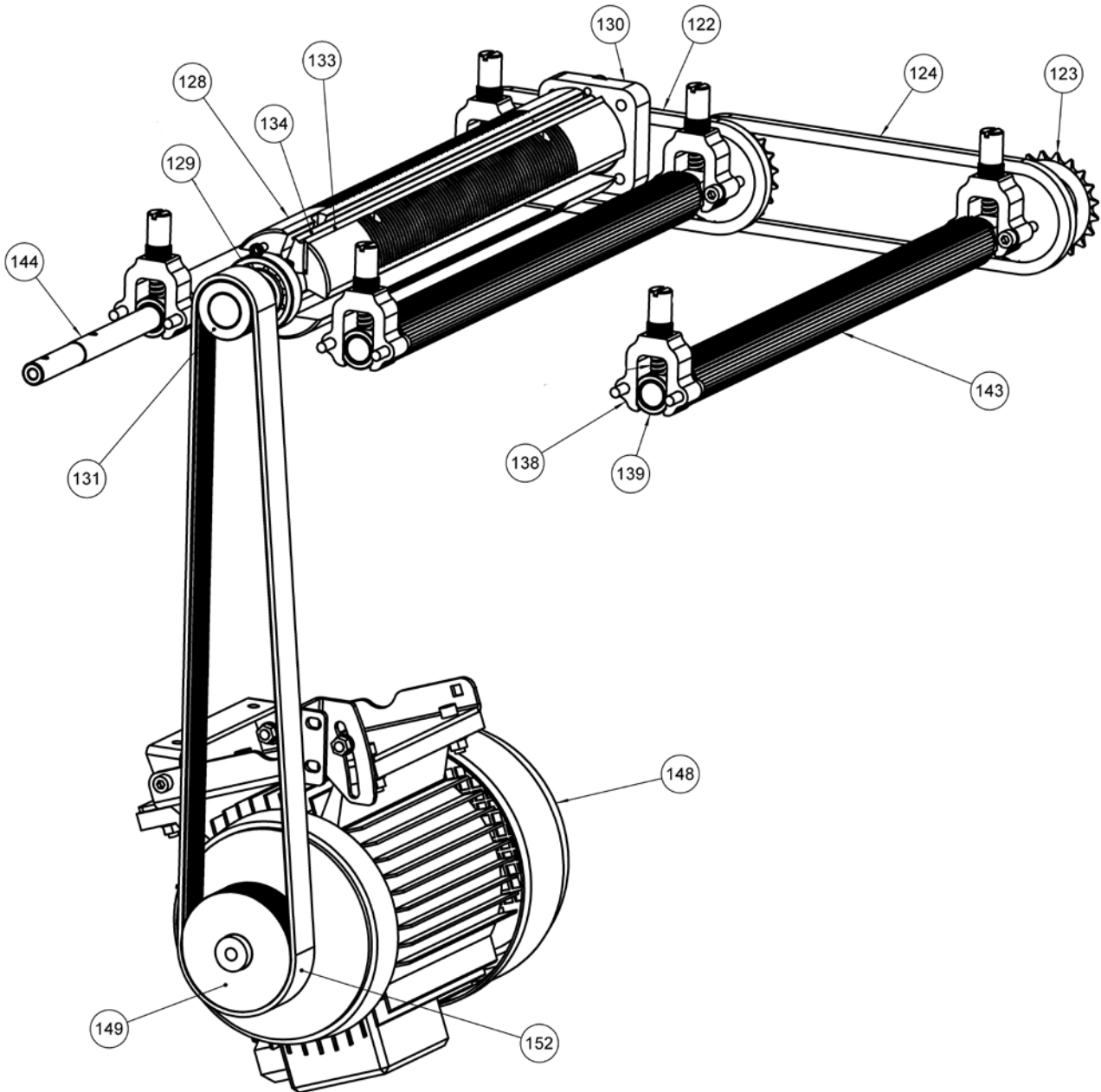









**Declaration of conformity  
The Machinery Directive 89/392/  
EEC**

Annex 2, section A  
AFS 1994:48, Annex 2, section A

Manufacturer  
MORETENS AB, M10  
Lugnviksvägen 147  
SE-831 52 ÖSTERSUND

hereby guarantees that the MORETENS PH360 Planer/moulder, No. 360-000 fulfills the requirements in AFS 1994:48 and 98/37/EC, The EMC Directive 2004/108/EC, standard EN61000-6-4 and the Low Voltage Directive 2006/95/EC

Östersund 2010

Bo Mårtensson, CEO



***Swedish wood processing products***

**LOGOSOL SWEDEN**

Fiskaregatan 2, SE-871 33 Härnösand, Sweden  
Tel. +46 (0)611-18285 | Fax +46 (0)611-182 89  
info@logosol.se | www.logosol.se