

LOGOSOL

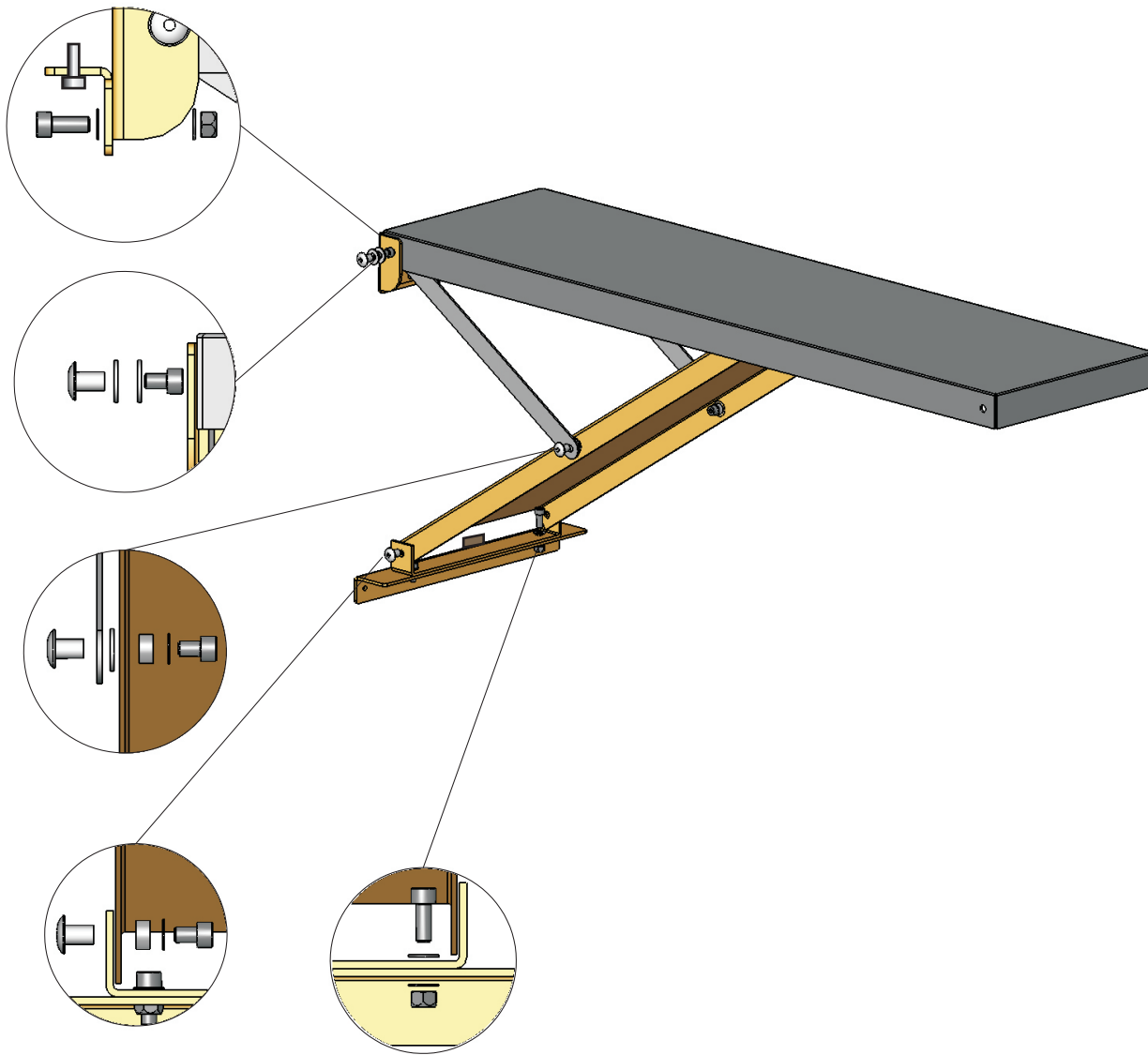

1.Align the feeding table to the cast iron table at its top mount.
2.Adjust the table's angle.

MKS M8	6
Nut M8	4
Screw M8x20	6
Screw M8x10	6
Washer 10,5x22x2	6
Washer 8,4x16x1,51	4
Plastic pipe	4